

BICYCLE LANE PAVEMENT SYMBOL AND MESSAGES

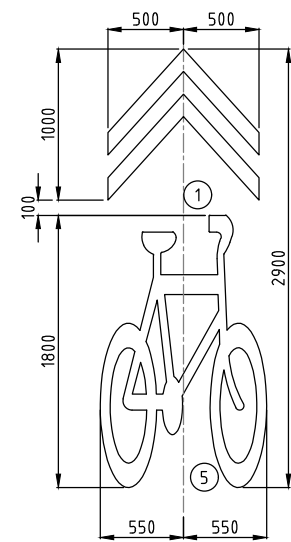

TYPICAL SYMBOL ASSEMBLY FOR USE IN RETROFIT ON MAJOR COLLECTOR STREETS

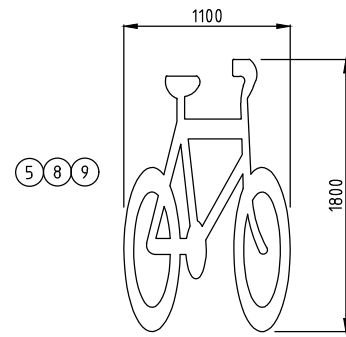

BICYCLE PAVEMENT MARKING CAD CODE: CYCLE FOR USE ON BICYCLE LANES AND MARKED SHOULDERS ONLY

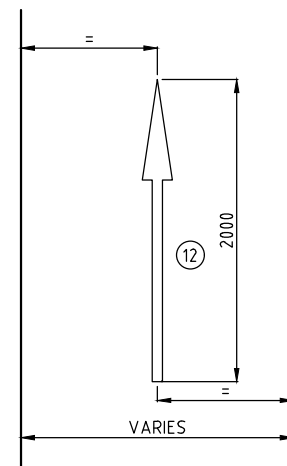

STRAIGHT

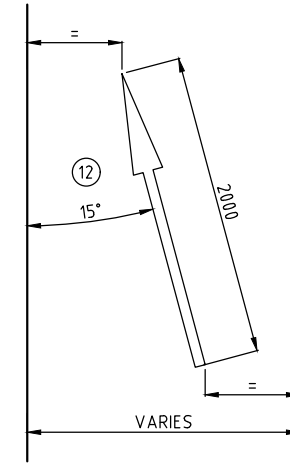

OBLIQUE

ARROW FOR USE ON BICYCLE LANES AND MARKED SHOULDERS ONLY BOQ CODE A10 (AREA 0.166m²)

FOR USE ON MAIN AND LOCAL ON-ROAD CYCLING ROUTES

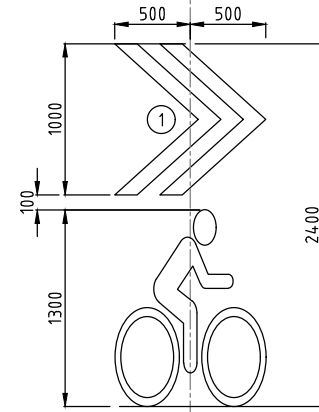
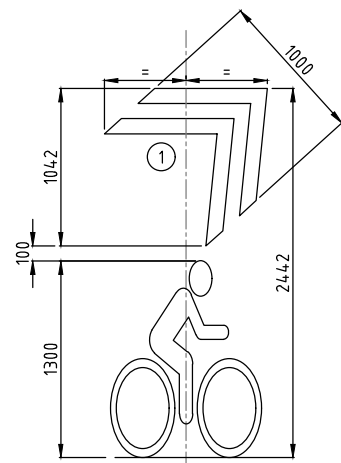
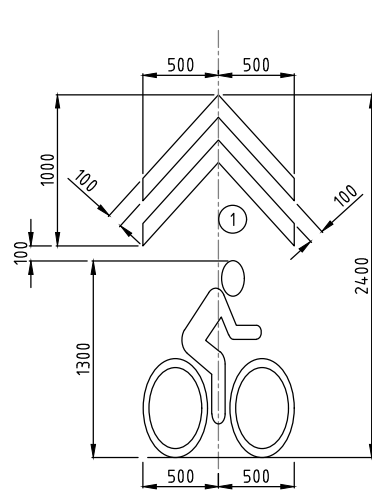

TYPICAL SYMBOL ASSEMBLY SYMBOLS FOR BICYCLE BOULEVARDS (ACTIVE TRAVEL STREETS)

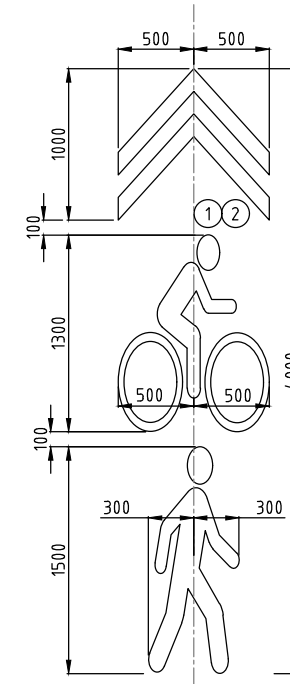

TYPICAL SYMBOL ASSEMBLY SYMBOLS FOR STREETS WITHOUT PATHS (GENERALLY RETROFIT ONLY)

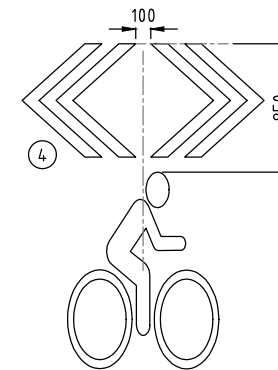
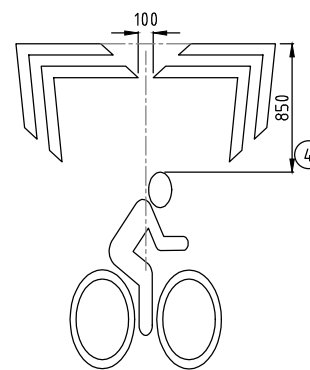
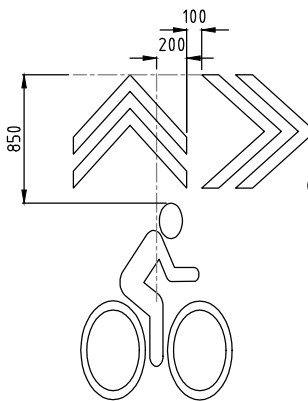
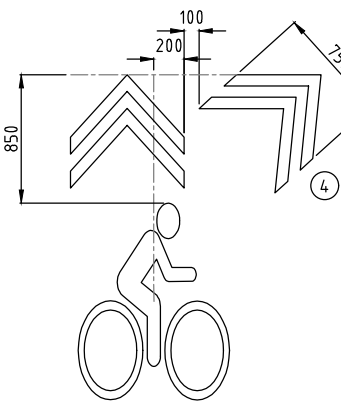
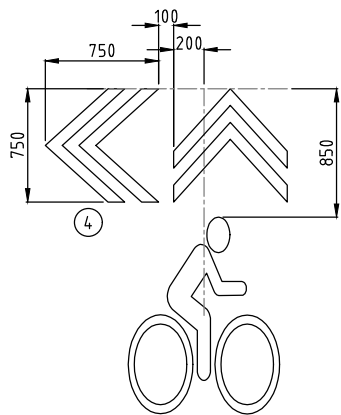
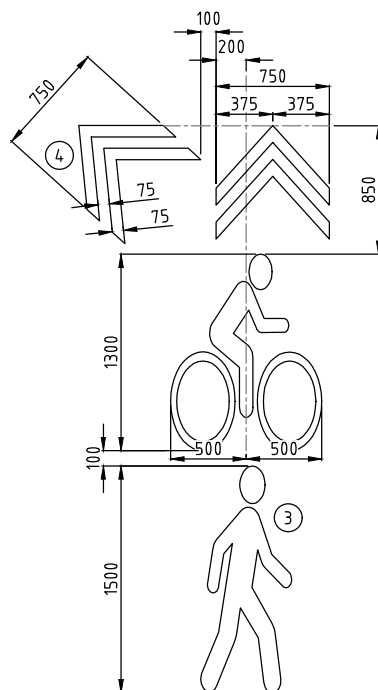

TYPICAL SYMBOL ASSEMBLY SYMBOLS ASSEMBLY ON INTERSECTION APPROACHES (REDUCED SHARROW SIZE)

FOR USE ON MAIN AND LOCAL COMMUNITY ROUTES

NOTES:

- ① THE SINGLE SHARROW IS SPACED ALWAYS 0.1m FROM THE SYMBOL BELOW. THE SHARROW IS ALWAYS LATERALLY CENTRED ON THE SYMBOL GROUP CENTRELINE
- ② SINGLE SHARROW, CYCLIST AND WALKER COMBINATIONS ARE SETOUT WITH THE SAME SPACINGS AS THE SINGLE SHARROW AND CYCLIST COMBINATIONS
- ③ THE WALKER SYMBOL IS TO BE INCLUDED ON STREETS WITHOUT PATHS AT INTERSECTION APPROACHES WITH DIMENSIONING AS PER THE TYPICAL SYMBOL ASSEMBLY
- ④ WHERE MULTIPLE SHARROWS ARE USED THE SHARROW SHALL BE 75% THE SIZE OF THE SINGLE SHARROW. THE SHARROWS SHALL BE SPACED 100mm FROM EACH OTHER. THE TOP OF THE SHARROWS IS TO BE 850mm ABOVE THE TOP OF THE CYCLIST MARKING. THE LATERAL POSITION IS TO BE AS SHOWN
- ⑤ REFER TO AS1742.9 FIGURE 3.1 FOR BICYCLE PAVEMENT SYMBOL DETAILS
- ⑥ WALKER AND CYCLIST SYMBOLS ARE BASED ON SYMBOLS USED ON SIGNS AND PATHS. THEY ARE VERTICALLY ELONGATED 150%. REFER TO ACT GOVERNMENT WEBSITE FOR PAVEMENT SYMBOL EPS FILES
- ⑦ ALL DIMENSIONS SHOWN ARE IN mm UNLESS SHOWN OTHERWISE
- ⑧ FOR USE ON BICYCLE LANES AND MARKED SHOULDERS ONLY;
 - COLOUR - WHITE
 - USE - DELINEATION OF BICYCLE LANES OR MARKED SHOULDERS
 - MATERIAL - PAINT (EXCEPT USE LLM IN HIGH WEAR AREAS EG ADJACENT TO C1/C2)
- REFER TO MIS05 7.1 FOR DETAILS
- ⑨ SIZE OF BICYCLE PAVEMENT MARKING CAN BE SCALED DOWN TO FIT WITHIN BICYCLE LANE. APPROXIMATE HEIGHT TO WIDTH RATIO MUST BE MAINTAINED
- ⑩ PAVEMENT MESSAGE "END" IS USED IN SPECIFIC CIRCUMSTANCES REFER TO ACTSD-0540 FOR REQUIREMENTS
- ⑪ PAVEMENT TEXT IS BASED ON A SCALED DOWN VERSION OF 2.5m HIGH PAVEMENT LETTERS IN AS1742.2 FIGURE 5.7
- ⑫ ARROW IS BASED ON THE STRAIGHT AHEAD ARROW AS1742.2 FIGURE 5.9(a) SCALED DOWN TO 2.0m IN LENGTH. ARROW SYMBOL IS TO BE STRAIGHT OR ANGLED AT 15°



ACTIVE TRAVEL ROADWAY PAVEMENT MARKINGS

Authorised: *[Signature]*

Latest Revision Details

0	BASED ON DRG DS9-02	19-12-18
Rev	Amendment	Date
Drawing No. ACTSD-3523		Revision 0