

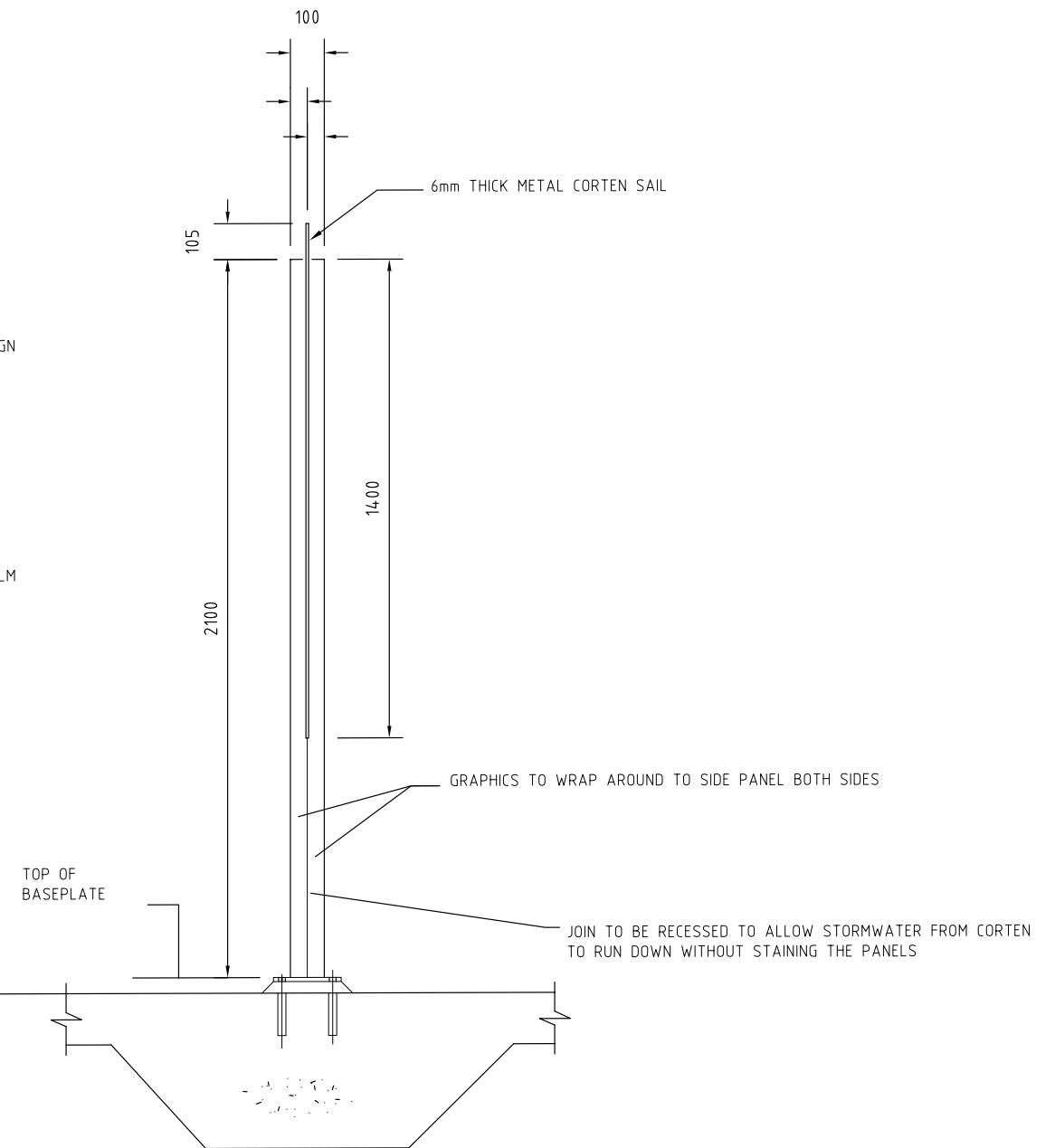

**ELEVATION**  
1:20



**ELEVATION**  
1:20

 <b>ACT</b> Government		
<b>STANDARD DRAWING</b>		
<b>SIGNAGE STANDARD DETAIL SHEET 8</b>		
Authorised: 		
Latest Revision Details		
0	FIRST ISSUE	25-2-19
Rev	Amendment	Date
Drawing No. ACTSD-2516		Revision 0