

TYPICAL LAYOUT
N.T.S.

REQUIREMENTS IN RETROFIT

THE REQUIREMENTS OUTLINED ON THIS DRAWING APPLY TO THE DESIGN AND CONSTRUCTION OF NEW BUS STOPS.

FOR RETROFIT OF EXISTING BUS STOPS SOME OF THESE REQUIREMENTS MAY NOT BE ACHIEVABLE, OR ECONOMICALLY JUSTIFIABLE, DUE TO THE CONFIGURATION OF THE EXISTING BUS STOP PADS AND OTHER FEATURES. TO ENSURE THAT THE INTENT OF AS1428 REQUIREMENTS ARE ACHIEVED ANY MODIFICATIONS TO THIS DRAWING FOR THE PURPOSE OF UPGRADING EXISTING BUS STOPS MUST FIRST BE APPROVED BY THE ROAD AUTHORITY (DIRECTOR ROADS ACT OR HIS/HER REPRESENTATIVE).

NOTES

- WHERE PRACTICABLE BUS STOPS SHOULD BE LOCATED ON STRAIGHT OR LARGE RADIUS CURVES AND ON LONGITUDINAL ROAD GRADES PREFERABLY NOT EXCEEDING 2.5%. SPECIAL APPROVAL BY THE ROAD AUTHORITY MAY BE GRANTED ON ROADS IN EXCESS OF THIS GRADE.
- TACTILE GROUND SURFACE INDICATORS (TGSI's) SHALL BE FULLY VITRIFIED PORCELAIN TILES NOMINAL DIMENSIONS 300 x 300 x 12 DEEP INSTALLED IN ACCORDANCE WITH THE MANUFACTURER'S RECOMMENDATIONS AND AS1428.4-2002. THE BODY OF THE TILES IS TO BE FLUSH WITH THE SURROUNDING SURFACE WITH RAISED INDICATORS TO BE PROUD OF THE SURFACE.
- TACTILE GROUND SURFACE INDICATORS (TGSI's) SHALL HAVE A LUMINANCE CONTRAST TO THE SURROUNDING SURFACE - REFER TO MIS05 5.5 FOR REQUIREMENTS.
- THESE TYPICAL DETAILS ALLOW FOR THE PROVISION OF SEATING AND/OR SHELTERS ON THE BUS STOP PAD FOR DESIGN PURPOSES. THE ROAD AUTHORITY WILL ADVISE WHETHER A SEAT OR SHELTER IS REQUIRED ON ANY GIVEN BUS STOP PAD. ALL SEATS AND SHELTERS ARE TO BE TO THE ROAD AUTHORITIES APPROVAL.
- SIGNAGE RELATING TO INFORMATION SUCH AS ROUTE AND TIMETABLE INFORMATION IS THE RESPONSIBILITY OF THE BUS OPERATOR AND NOT INCLUDED ON THIS DRAWING. BUS STOP PAD DIMENSIONS MAY REQUIRE ADJUSTMENT TO ALLOW FOR TIMETABLE SIGNAGE.
- REFER ACTSD-0531 FOR BUS STOP DETAILS WHERE THE PATH IS LOCATED AWAY FROM THE KERB. WHERE THE PATH IS LOCATED IN A POSITION NOT SHOWN IN ACTSD-0530 OR ACTSD-0531, THE DESIGNER SHALL FIRST ASSESS THE LOCATION AND THEN LIAISE WITH THE ROAD AUTHORITY REGARDING THE APPROACH PATH ALIGNMENT.
- SHELTER ROOF OVERHANGING OR WITHIN 300 OF A PATH SHALL BE 2500, TO THE MINIMUM UNDERSIDE OF THE STRUCTURE.
- THE MINIMUM SIZE PAD MAY NOT BE ABLE TO BE ACCOMMODATED AT SOME LOCATIONS DUE TO THE LIMITED AVAILABLE SPACE, TERRAIN, SLOPE OR OTHER CONSTRAINTS. UNDER THESE CIRCUMSTANCES THE ROAD AUTHORITY SHALL BE CONSULTED TO RESOLVE ALTERNATIVE OPTIONS.
- ALL NEW KERB (INCLUDING TRANSITIONS) IS TO BE THICKENED TO 200mm DEPTH AND REINFORCED.
- THE BUS STOP PAD SIZE ILLUSTRATED AS DETAILED IS BASED ON A NOMINAL 3750 x 1350 (EXCLUDING ROOF OVERHANG) SHELTER SIZE. WHERE A LARGER SHELTER IS USED THE PAD SIZE SHALL BE INCREASED BY AT LEAST THE DIRECT SHELTER SIZE INCREASE.
- THE MINIMUM CLEARANCE TO THE WHEELCHAIR SPACE MAY NOT BE ACHIEVABLE WHERE EXISTING PATHS ARE WIDER THAN 1200 AND SPACE IS LIMITED, AND / OR WHERE SIGHT DISTANCE MAY BE COMPROMISED. UNDER THESE CIRCUMSTANCES THE DESIGNER MUST ENSURE THAT ADEQUATE PATH CLEARANCES ARE RETAINED OR APPROPRIATE WARNING DEVICES PROVIDED, AS APPROVED BY THE ROAD AUTHORITY.
- ALTERNATIVE LOCATION OF BUS STOP SIGN FOR FOOTPATHS 2000 WIDE (OR GREATER) IN URBAN AREAS LOCATED ON AN ACCESS COMMUNITY ROUTE SUBJECT TO APPROVAL BY THE ROAD AUTHORITY.
- FOR BUS STOP PAVEMENT MARKINGS REFER ACTSD-3510 FOR DETAILS.
- PATHS FORMING A PART OF A MAIN OR LOCAL COMMUNITY ROUTE ARE NOT TO BE LOCATED BETWEEN A BUS STOP AND KERB. IN THIS CIRCUMSTANCE THE PATH MUST BE REALIGNED AROUND THE REAR OF THE BUS STOP. PATH CONNECTION IS TO BE PROVIDED FROM THE REALIGNED PATH TO THE BUS STOP PAD.
- THE BUS STOP SIGN POST SHALL BE 60.3/2.9/GR350. AN ALUMINIUM SIGN FOOTING SOCKET SYSTEM SHALL BE INSTALLED IF THE SIGN IS IN A CONCRETE OR PAVED SURFACE. THE SIGN BLADE IS TO BE SUPPLIED BY THE BUS OPERATOR AND INSTALLED BY THE CONTRACTOR. THE SIGN SHALL BE ORIENTATED AWAY FROM THE KERB IF IN CLOSE PROXIMITY TO THE KERB. THE MINIMUM SIGN MOUNTING HEIGHT SHALL BE 2.5m FROM FINISHED SURFACE LEVEL TO UNDERSIDE OF BLADE.

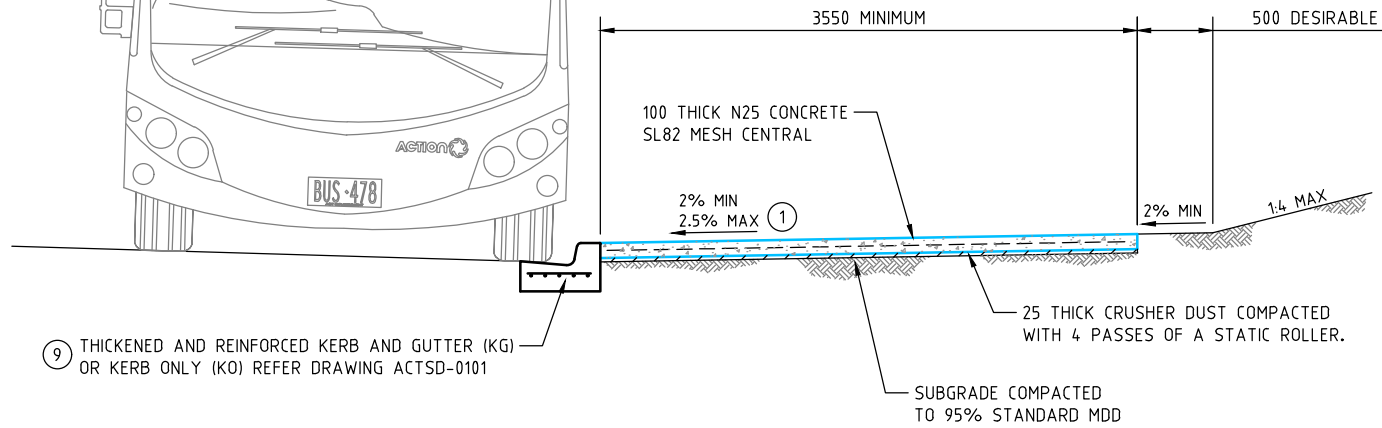
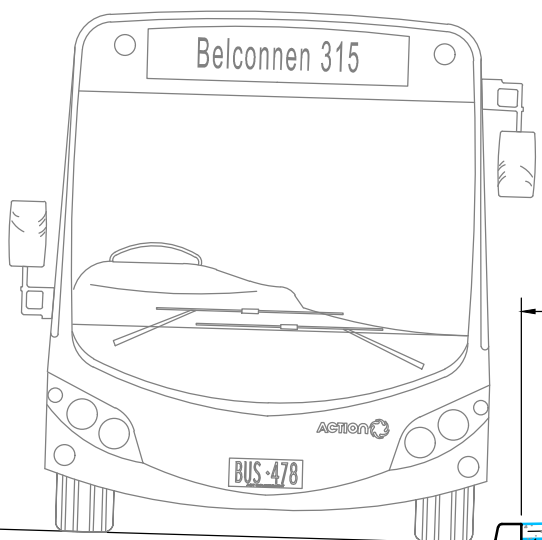

CROSS SECTION A-A
N.T.S.

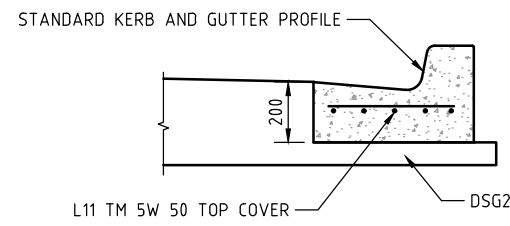

REINFORCED BUS STOP KERB AND GUTTER DETAIL
N.T.S.

ACT Government

STANDARD DRAWING

BUS STOP STANDARD DETAILS
CONNECTING PATH BEHIND KERB

Authorised: *[Signature]*

Latest Revision Details

1	DIMENSIONS UPDATED	09/11/20
0	BASED ON DRG DS13-03-1	28/09/18
Rev	Amendment	Date
Drawing No. ACTSD-0530		Revision 1