

**BEND CONSTRUCTION
DETAIL**

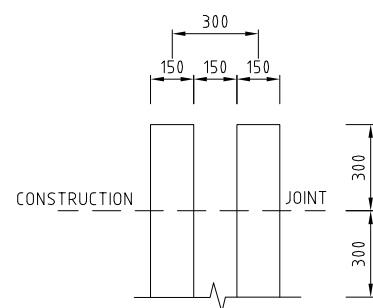

**SPLICE BAR
DETAIL B**

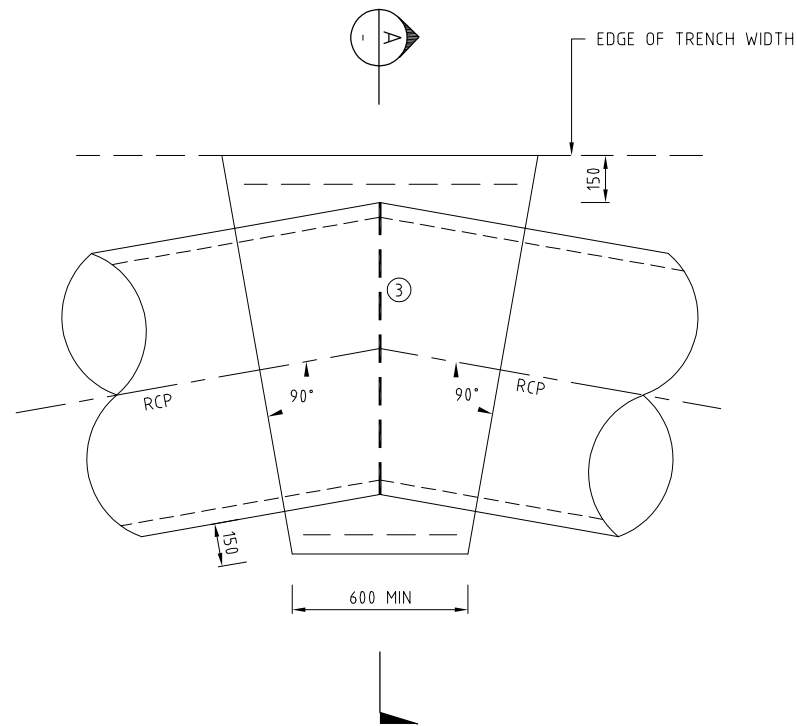

**BANDAGE JOINT PLAN
DETAIL A**

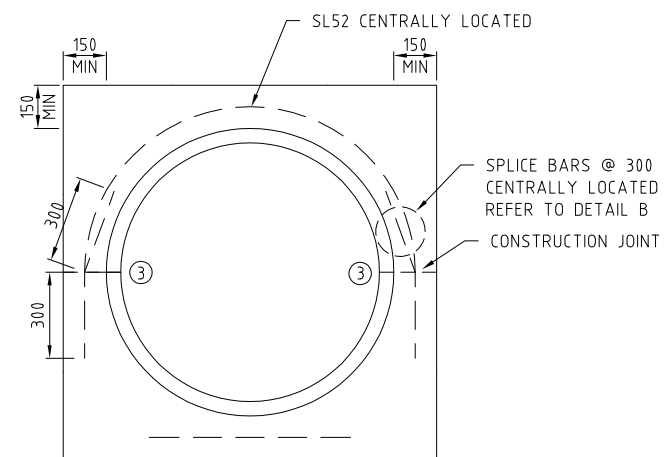

TYPICAL SECTION A

NOTES:

1. REFER TO DRAWING ACTSD-0000 FOR GENERAL NOTES.
2. MINIMUM CONCRETE GRADE N32 TO AS 3600.
- ③ INSIDE OF JOINT TO BE FILLED WITH MORTAR FOR PIPES 900 OR LARGER.
4. CONCRETE IS NOT TO PROJECT INTO WATERWAY.
5. PIPES < 750Ø JUNCTION TO BE USED AT CHANGE OF DIRECTION.
6. HORIZONTAL SPLAYED PIPE SHALL BE USED FOR DEFLECTION > 10°.
7. FOR DEFLECTION < 10° USE BEND OR BENCHING AT JUNCTION.
8. RADIUS SHOWN IS A MINIMUM RADIUS AND SHALL BE USED UNLESS OTHERWISE SPECIFIED.

TABLE 1 : MINIMUM DIMENSIONS FJ SPLAYS

D	SINGLE ENDED SPLAYS		DOUBLE ENDED SPLAYS	
	MIN R	MIN β	MIN R	MIN β
750	12.2	5°37'03"	4.6	14°37'15"
825	12.4	5°31'39"	4.9	13°45'38"
900	12.6	5°26'25"	5.2	12°59'40"
1050	13.0	5°16'26"	5.8	11°41'21"



**ACT
Government**

STANDARD DRAWING

**RCP SPLAYED
PIPE DETAILS**

NOT TO SCALE

Authorised: *[Signature]*

Latest Revision Details

Rev	Amendment	Date
0	BASED ON DRG ST-0002	14/01/19
Drawing No. ACTSD-0803		Revision 0