

**NOTES:**

1. ALL DIMENSIONS SHOWN ARE IN mm.
2. COLUMN DESIGN TO COMPLY WITH AS 1170 & AS 1798.
3. ALL WELDING TO COMPLY WITH AS 1554.
4. GALVANIZING TO CONFIRM TO AS/NZS 4680.
5. PAINT FINISH TO AS 3887 CATEGORY LONG TERM.

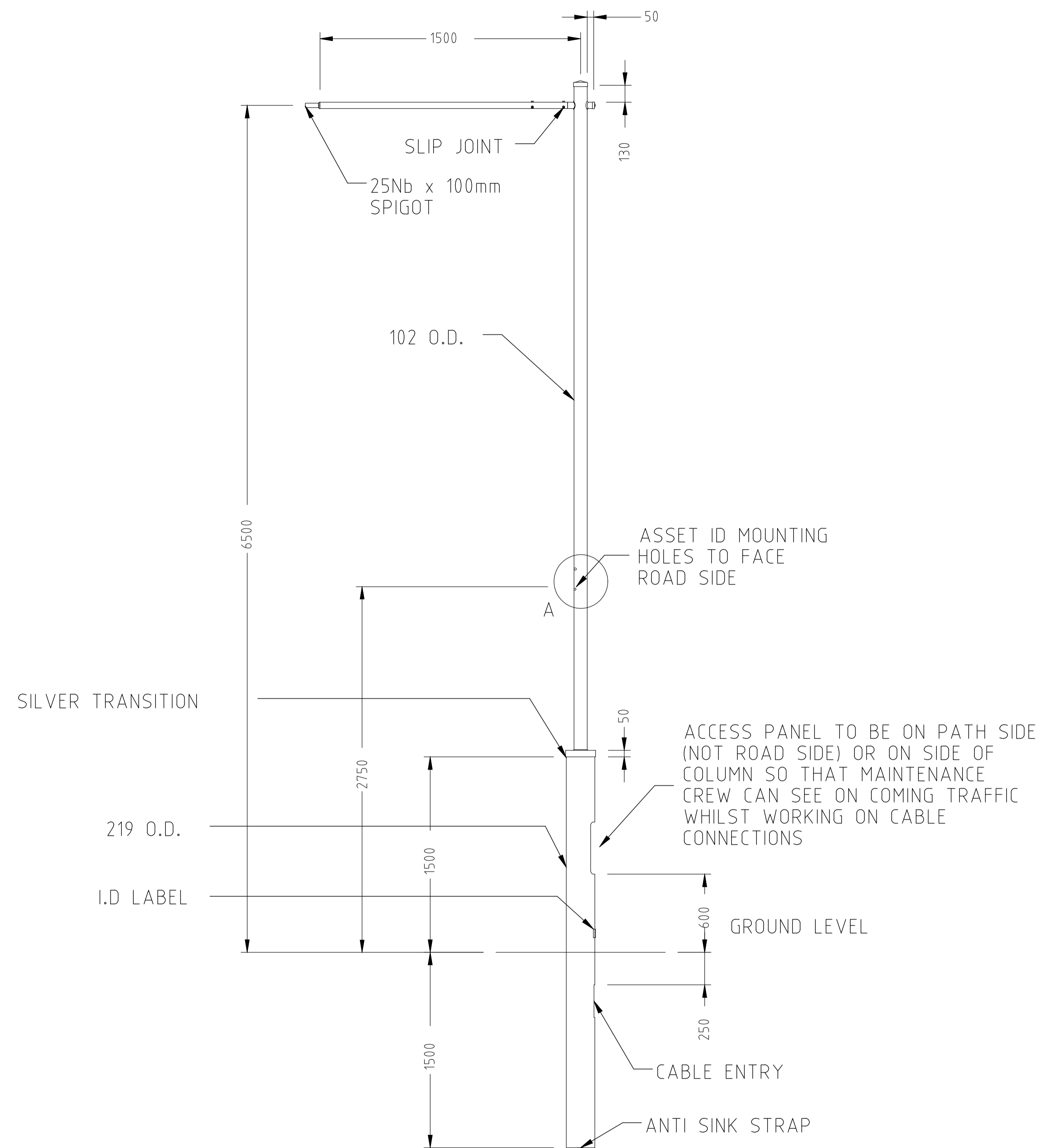

**SIDE VIEW**

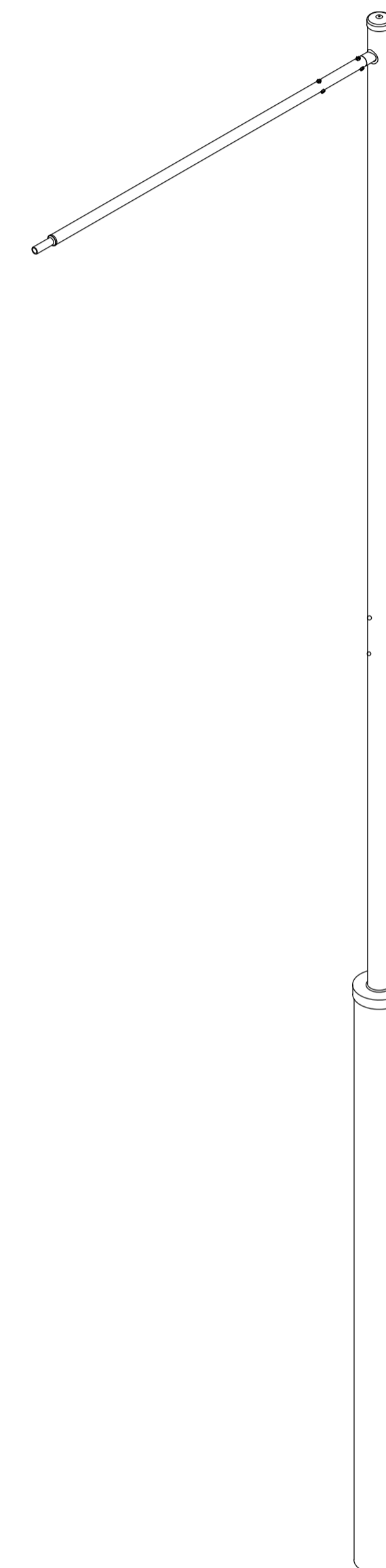

**ISO VIEW**

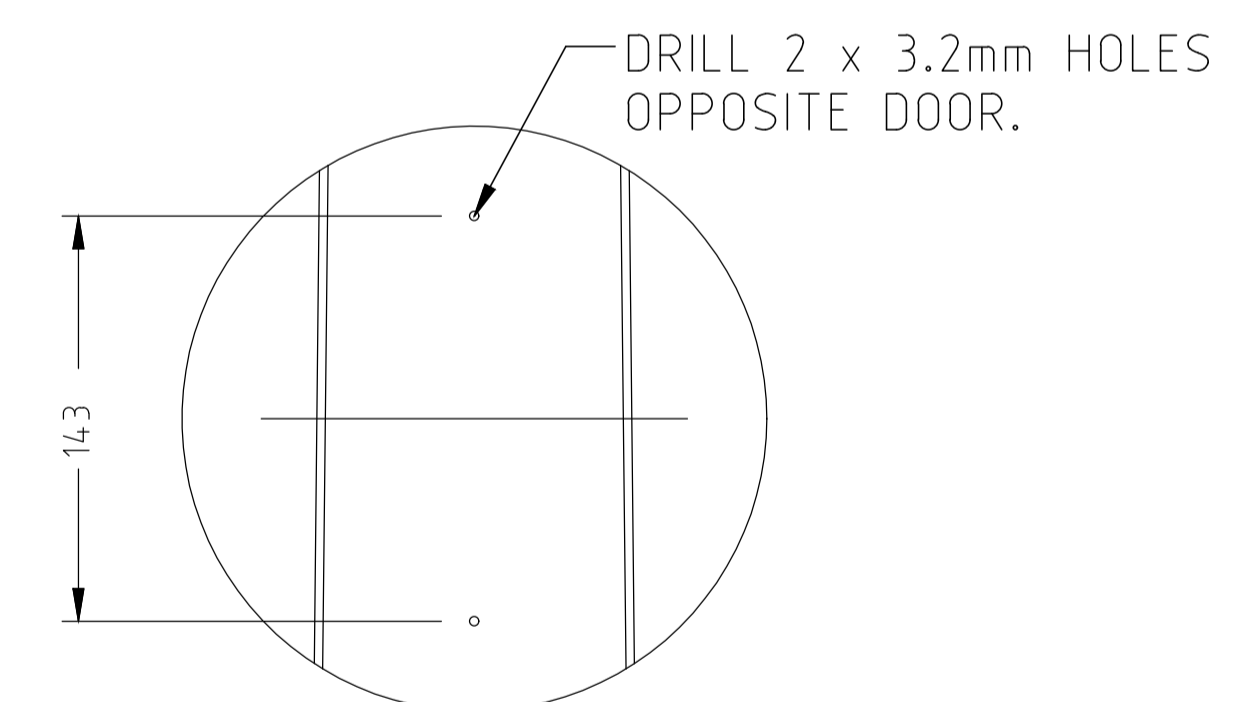

**SIDE ELEVATION A**



**STANDARD DRAWING**

**6.5m SINGLE FORDE DECORATIVE COLUMN DIRECT BURIED**

DRAWING NOT TO SCALE - N.T.S.

Authorised:

Latest Revision Details

Rev	Amendment	Date
0	BASED ON DRG 0512-03-20	21/12/21

Drawing No.      Revision

**ACTSD-4120**

**0**

COLOUR: CHARCOAL GREY 32999 c/w SILVER TRANS