



ACT
Government

Construction in the vicinity of stormwater easements

Summary of requirements

March 2008

Contents

1. Introduction	3
2. Structures permitted in easements	3
3. Structures prohibited in easements	3
4. Design requirements	4
4.1 Carports.....	4
4.2 Walls and fences.....	5
4.3 Cantilevered overhangs.....	5
4.4 Trees and vegetation.....	5
4.5 Concrete slabs.....	7
4.6 Structures next to easement.....	8
5. Submission requirements	8

1. Introduction

On some properties, municipal services have been constructed within the leased land. Shared use of this land is possible, but the presence of the service constrains the possible development in the vicinity of the municipal service. In most cases, an easement is shown on the Deposited Plan for the lease. The purpose of the easement is to protect the municipal service, allow access for operation, repair and maintenance, and to protect improvements to the lease made by the lessee.

2. Structures permitted in easements

The following structures will be permitted within easements subject to compliance with the conditions set out in this document:

1. Carports
2. Walls and fences (retaining walls, screen walls, fences and gates)
3. Cantilevered overhangs
4. Concrete slabs
5. Small trees and vegetation

3. Structures prohibited in easements

Permanent structures such as the following will not be permitted within easements:

1. New dwellings & buildings
2. Extensions to existing dwellings & buildings
3. Lockable structures including garages, store rooms, tool sheds, gazebos, aviaries, garden sheds, and green/glass houses
4. Swimming pools, water tanks, non-municipal stormwater structures, electrical & gas appliances and other fittings and fixed structures
5. Lockable roller doors, tilt doors and like fittings
6. Supports for decks, balconies, building overhangs and the like

4. Design requirements

The following sections summarise the requirements of Asset Acceptance in respect to the construction of works in the vicinity of stormwater easements.

Construction of works in the vicinity of stormwater reserves should be brought to the attention of Asset Acceptance for consideration and, if necessary, setting of specific site requirements.

All designs shall be in accordance with the standards of the ACT Government.

The depth of earth cover over a buried service pipe within the easement shall not be reduced without the prior approval of Asset Acceptance and shall under no circumstance be reduced to less than 0.6 m. Also, the earth cover over a buried service pipe shall not be increased beyond the depth recommended by the pipe manufacturer for that class of pipe and bedding in that cover situation. This information may be obtained from Asset Acceptance or the relevant pipe manufacturer.

The footings or foundations of all structures within and adjacent to stormwater easements shall be deep enough such that the structure does not put any loading on the buried service pipe. The loading zone of influence shall pass beneath the buried service pipe as shown on Figures 1 and 2.

4.1 Carports

Non-demountable and demountable carports shall be designed and constructed in accordance with the following requirements. Refer to Figure 1 for details.

1. The horizontal distance between the carport supports and the centreline of the buried service pipe shall not be less than 900 mm.
2. The carport supports on the lease boundary side shall not encroach more than 300 mm into the easement.
3. The clear height between the finished surface level and the underside of that part of the roof structure over the easement shall not be less than:

Non-demountable carports 2.7 m

Demountable carports 2.1 m

4. Construction joints shall be provided:
 - along one or both sides of the buried service pipe at a minimum offset of $0.5 + D/2$ metres from the pipe centreline, where D is the nominal diameter of the buried service pipe
 - at not more than 2 m spacing transversely across the easement

5. For demountable carports:
 - the carport structure shall be readily demountable and able to be re-erected without the need to replace major building components. The Building application plans for the structure shall show the details of jointing
 - the roof shall not be a continuation of the dwelling or other building roof structure

4.2 Walls and fences

Retaining walls, screen walls, fences and gates and other like structures shall be designed and constructed in accordance with the following requirements. Refer to Figure 2 for details.

1. The structure shall be shown on the Building Application plan(s).
2. The structure within the easement shall be aligned nominally parallel to the buried service pipe with a minimum clear distance of 900 mm to the centreline of the buried service pipe.
3. Any part of the structure crossing the easement shall be kept to a minimum with the crossing being less than 45° to a right angle crossing of the easement.
4. Construction joints shall be provided at either end of the easement crossing.
5. The foundations of that part of the structure which crosses the easement, and hence the buried service pipe, shall bridge over the whole width of the easement.
6. The structure shall not concentrate overland stormwater flows onto adjoining leases or across road verges.

4.3 Cantilevered overhangs

Cantilevered overhangs shall be designed and constructed in accordance with the following requirements.

1. The clear height between the finished surface level and the underside of that part of the overhang over the easement shall not be less than 2.7 m.
2. Supports for overhangs are not permitted within easements.

4.4 Trees and vegetation

Trees shall not be planted within the stormwater easement.

Small shrubs (height <1.5 m) and vegetation may be planted within the stormwater easement. However, shrubs and vegetation selected should have shallow root systems to minimise the likelihood of root penetration into the buried service pipe. It is advisable to talk to a landscaper or the local nursery for professional advice on suitable plants.

When planting next to a stormwater easement, it is advisable to locate trees no closer to the buried service pipe than recommended in the following table. The trees listed in the table are intended as a guide.

Suitable for planting no closer than 2m to pipe

Botanical name	Local name
Acacia buxifolia	Box-leaved Wattle
Banksia ericifolia	Heath Banksia
Callistemon citrinus	Crimson Bottlebrush
Euonymus japonica	Evergreen Spindle Tree
Genista tinctoria	Broom
Longerstroemia indica	Pink Crepe Myrtle
Malus (species)	Flowering Crabapples
Nerium oleander	Oleander
Pyracantha (species)	Firethorn
Viburnum tinus	Laurustinus

Suitable for planting no closer to 4m to pipe

Botanical name	Local name
Angpphora costata	Smooth-barked Apple Myrtle
Betula pendula	Silver Birch
Eucalyptus cinerea	Argyle Apple
Fraxinus excelsior "Aurea"	Golden Ash
Melaleuca armillaris	Bracelet Honey Myrtle
M. styphelioides	Prickly Paperbark
Sophora japonica	Pagoda Tree
Sorbus aucuparia	Rowan, Mountain Ash

NOT suitable for planting in the suburban environment

Botanical name	Local name
Acer negundo	Box Elder Maple
Casuarina cunninghamiana	River Oak
Celtis australis	Southern Nettle Tree
E. globulus	Californian Blue Gum
E. sideroxylon	Mugga or Red Ironbark
Fraxinus oxycarpa	Desert or Caucasian Ash
Pinus (species)	Pines
Populus (species)	Poplars
Quercus (species)	Oaks
Salix (species)	Willows
Ulmus (species)	Elms

4.5 Concrete slabs

Reinforced and non-reinforced concrete slabs, which do not form part of prohibited structures listed in Section 3, shall be designed and constructed in accordance with the following requirements. The purpose of the concrete slab shall be stated in the submission for approval.

1. The slab footing on the lease boundary side shall not encroach more than 300 mm into the easement. Refer to carport footing detail (b) in Figure 1 for details.
2. Construction joints shall be provided:
 - along one or both sides of the buried service pipe at a minimum offset of $0.5 + D/2$ metres from the pipe centreline, where D is the nominal diameter of the buried service pipe
 - at not more than 6 m spacing transversely across the easementNote: The above requirements do not apply to driveways.

4.6 Structures next to easement

Structures next to stormwater easements include the following situations:

- structures next to an easement in the same property as the structure
- structures next to an easement in an adjacent property

Structures next to easements shall comply with the following conditions. Refer to carport footing detail (a) in Figure 1 for details.

1. The foundation design details shall be submitted with the Building Application plans to Asset Acceptance.
2. Structures next to the easement that are in cut or fill shall have adequate space between the easement and the structure to provide a retaining structure and space for access, if required.

5. Submission requirements

For all structures within and/or adjacent to an easement, detailed designs shall be submitted with the Building Application plans to Asset Acceptance for an easement clearance prior to the commencement of construction.

Detailed design submissions shall include the following:

- site plan showing all information required by BEPCON Building Notes and other municipal utility information outside the lease
- details of roof connection method (frame) for a demountable carport or similar structure
- a cross-section at each end of the structure showing details of the buried service pipe and structure foundations. The cross-sectional elevation shall show the dimensional relationship between the structure foundation and the buried service pipe (refer to Form 1A which may be used for submission purposes)
- a certification by a chartered structural engineer stating that:
 - access to the buried service pipe or service connection ties will not be impeded
 - foundations will not impose adverse loads on the pipe
 - possible future trench excavations required to expose the pipe will not adversely affect the stability of the structure

Should there be any doubt as to whether a structure meets the requirements of this document, advice should be sought from Asset Acceptance prior to completing and submitting designs for approval.

Figure 1: Construction in the vicinity of stormwater easements for a carport layout

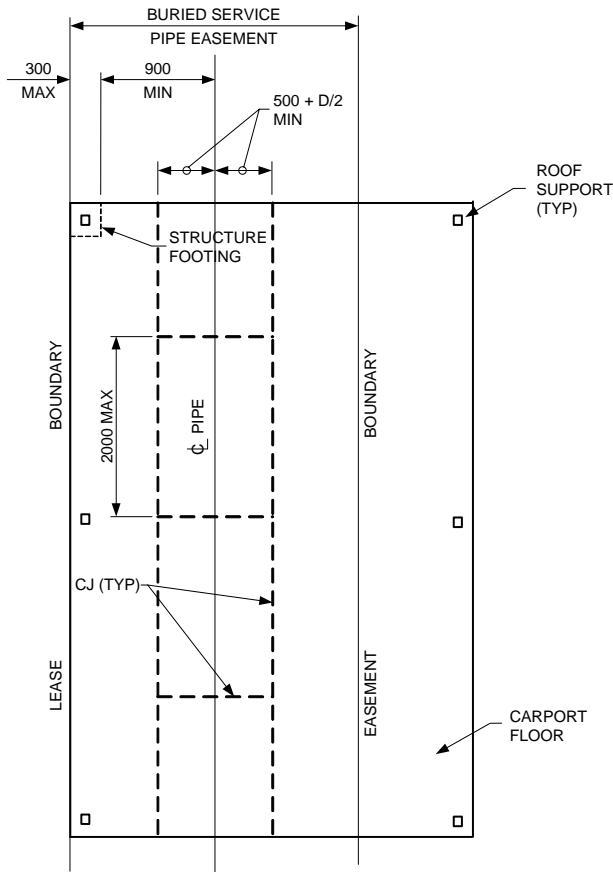

(a) SYMMETRICAL

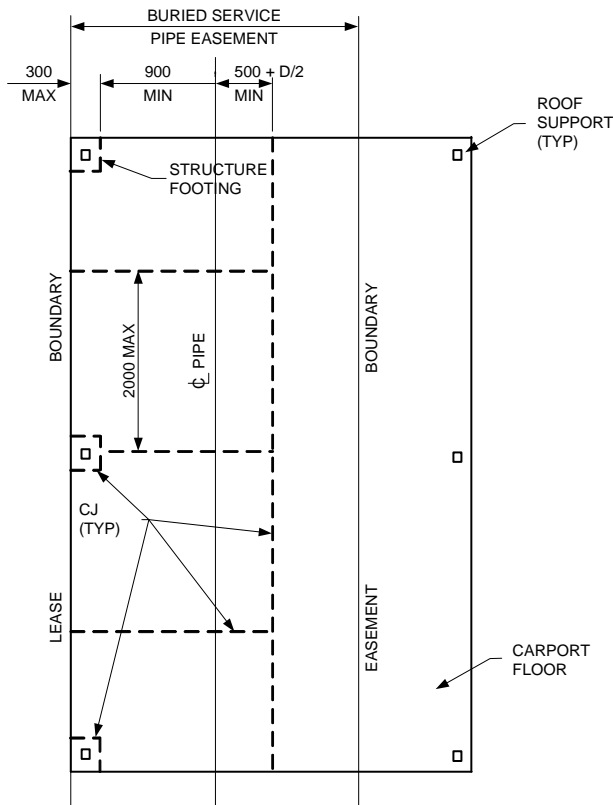

(b) NON-SYMMETRICAL

CARPORT LAYOUT

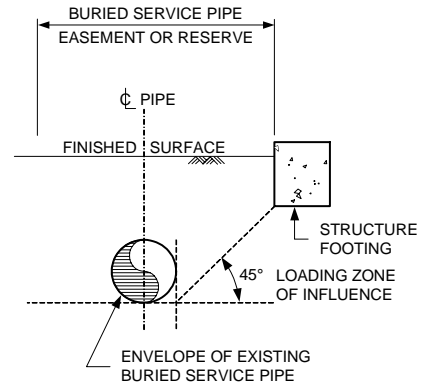

(a) FOOTING NEXT TO EASEMENT

NOTE: EASEMENT OR RESERVE MAY BE WITHIN OR NEXT TO LEASE

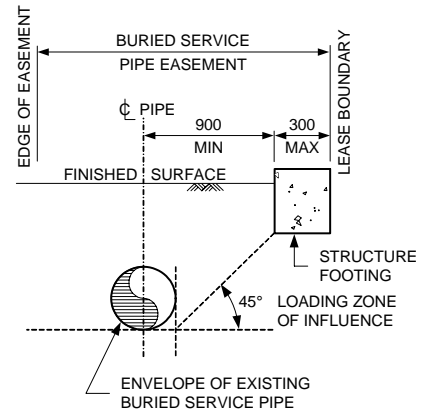

(b) FOOTING WITHIN EASEMENT

CARPORT FOOTINGS

NOTES :

1. CONCRETE FLOORS SHALL CONFORM TO THE REQUIREMENTS OF THIS DRAWING
2. CLEARANCE BETWEEN FINISHED FLOOR LEVEL AND UNDER SIDE OF ROOF SHALL BE :
 NON - DEMOUNTABLE STRUCTURE : 2.70 m
 DEMOUNTABLE STRUCTURE : 2.10 m
3. THE CARPORT SHALL BE DESIGNED AND CERTIFIED BY A PRACTICING CHARTERED STRUCTURAL ENGINEER WHO SHALL STATE THAT :
 (a) THE SUPPORTS WILL NOT IMPEDE ACCESS TO THE SERVICE PIPE OR SERVICE TIES
 (b) THE FOUNDATIONS WILL NOT IMPOSE ADVERSE LOADS ON THE PIPE
 (c) TRENCH EXCAVATIONS REQUIRED TO EXPOSE THE PIPE WILL NOT AFFECT THE STABILITY OF THE CARPORT FOUNDATIONS
4. BURIED SERVICE PIPE LOCATION, INVERT LEVEL AND SIZE TO BE CONFIRMED ON SITE AND STATED WITH SPECIFIC PROPOSALS
5. C.J: CONSTRUCTION JOINT TO BE AT MAX 2m SPACING AS SHOWN

CONSTRUCTION IN THE VICINITY OF STORMWATER EASEMENTS		
Not To Scale	CARPORTS	FIGURE 1
July 2000		

Figure 2: Construction in the vicinity of stormwater easements for walls and fences layout

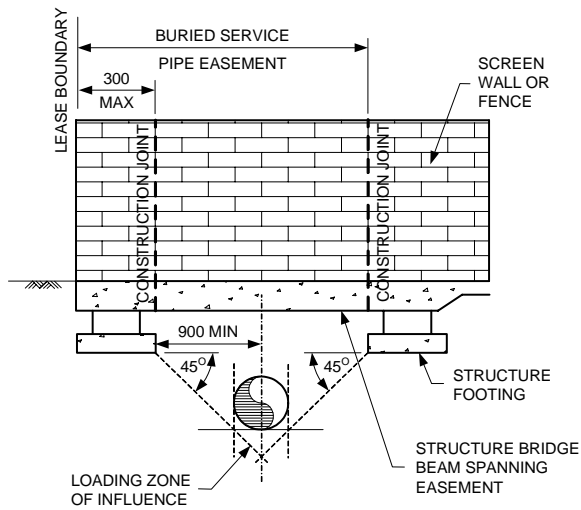

SECTION A
TYPICAL DETAIL

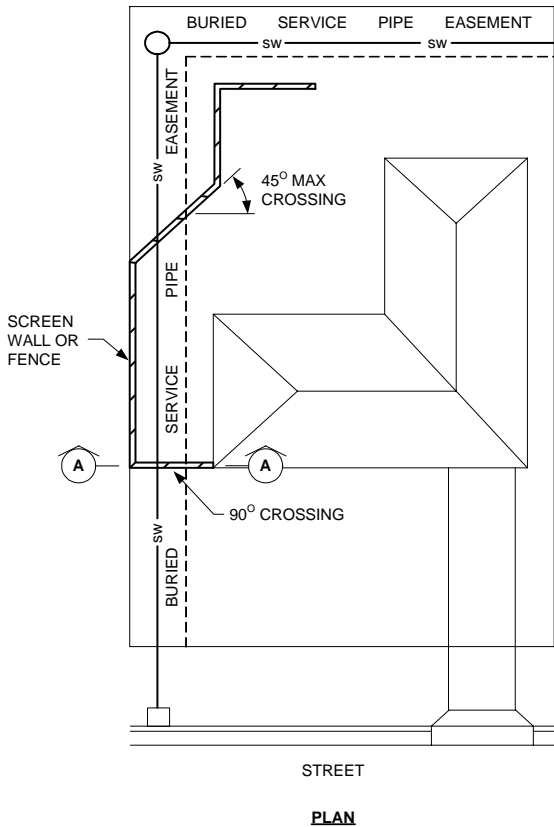

WALL & FENCE CROSSINGS

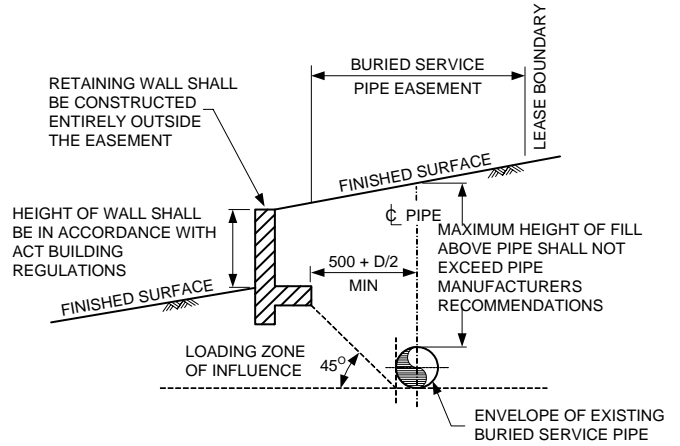

SECTION
RETAINING WALL IN FILL

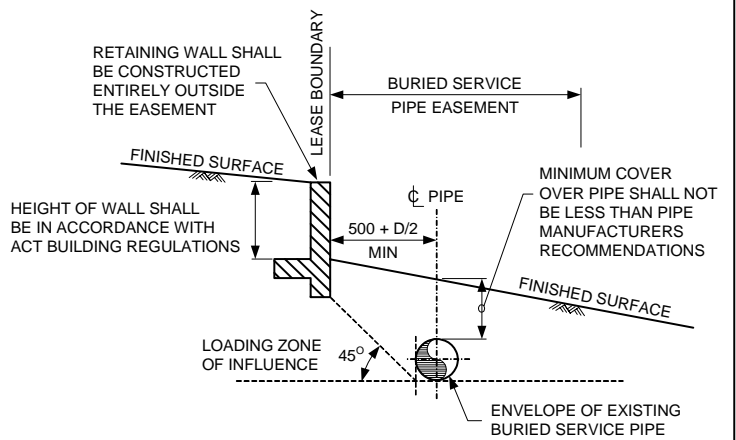

SECTION
RETAINING WALL IN CUT

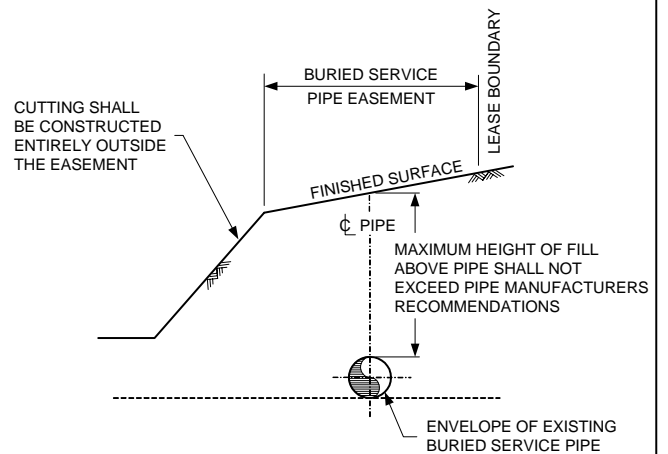

SECTION
SITE CUTTING (OR FILL)

RETAINING WALLS & CUTTINGS

NOTES:

1. WALLS & FENCES SHALL CONFORM TO THE REQUIREMENTS OF THIS DRAWING
2. RETAINING WALLS & FENCE STRUCTURES SHALL BE DESIGNED AND CERTIFIED BY A PRACTICING CHARTERED STRUCTURAL ENGINEER WHO SHALL STATE THAT :
 - (a) THE SUPPORTS WILL NOT IMPEDE ACCESS TO THE SERVICE PIPE OR SERVICE TIES
 - (b) THE FOUNDATIONS WILL NOT IMPOSE ADVERSE LOADS ON THE PIPE
 - (c) TRENCH EXCAVATIONS REQUIRED TO EXPOSE THE PIPE WILL NOT AFFECT THE STABILITY OF THE WALL OR FENCE FOUNDATIONS
3. BURIED SERVICE PIPE LOCATION, INVERT LEVEL AND SIZE TO BE CONFIRMED ON SITE AND STATED WITH SPECIFIC PROPOSALS

CONSTRUCTION IN THE VICINITY OF STORMWATER EASEMENTS		
Not To Scale	WALLS AND FENCES	FIGURE 2
July 2000		

Figure 3: Pipe and footing cross-section details

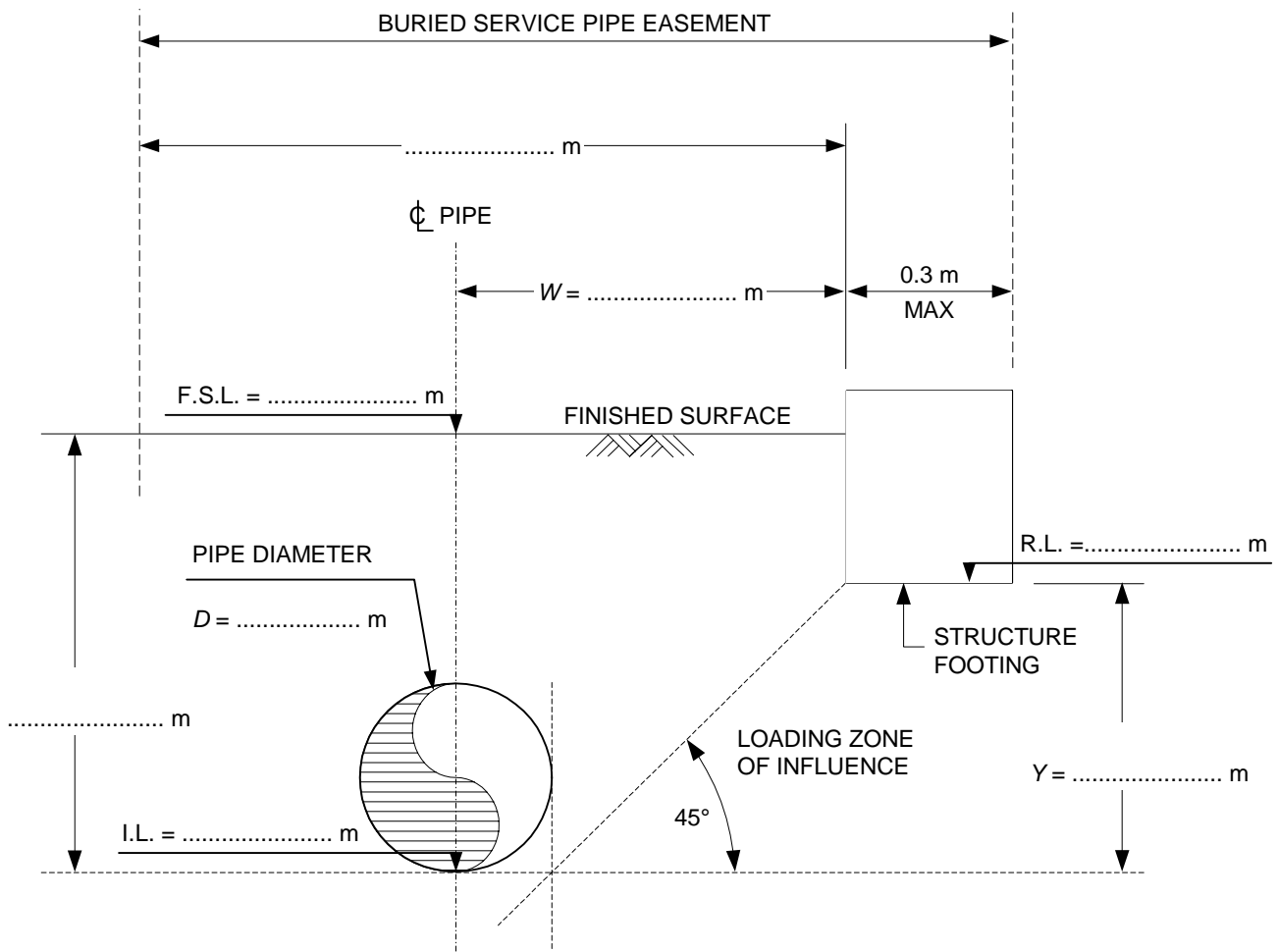

PIPE AND FOOTING CROSS-SECTION DETAILS

NOTES :

1. STRUCTURE FOOTINGS SHALL BE DEEP ENOUGH SUCH THAT THE STRUCTURE DOES NOT PUT ANY LOADING ONTO THE BURIED SERVICE PIPE. THE LOADING ZONE OF INFLUENCE SHALL NOT BE CLOSER TO THE BURIED SERVICE PIPE THAN AS SHOWN ABOVE BY ENSURING THAT :

$$Y \leq W - \frac{1.2D}{2}$$

2. BURIED SERVICE PIPE LOCATION, INVERT LEVEL AND SIZE TO BE CONFIRMED ON SITE AND STATED ON THE ABOVE DIAGRAM
3. SHOW LOCATION OF CROSS-SECTION ON DESIGN PLANS

PROJECT

SECTION No.

BLOCK SECTION SUBURB

.....