

GRID OF STANDARD SYMBOL

(VARIATIONS OF 100mm TO SUIT MANUFACTURERS TEMPLATE MAY BE ACCEPTABLE)

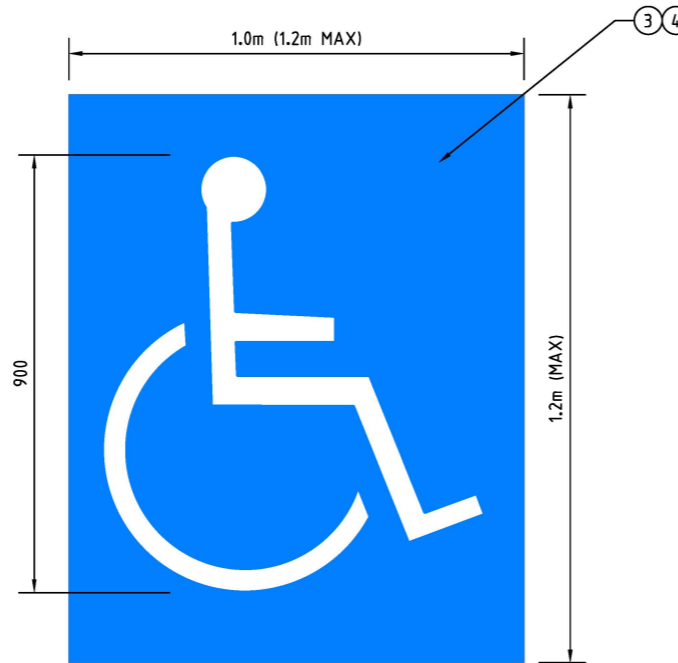

SYMBOL OF ACCESS FOR PAVEMENTS

CAD CODE: WB-ACCESS, COLOR: WHITE ON ULTRAMARINE BLUE

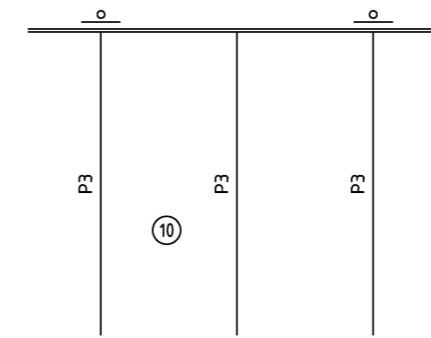

ANGLE CARPARK MARKING

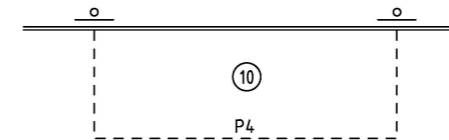

PARALLEL CARPARK MARKING

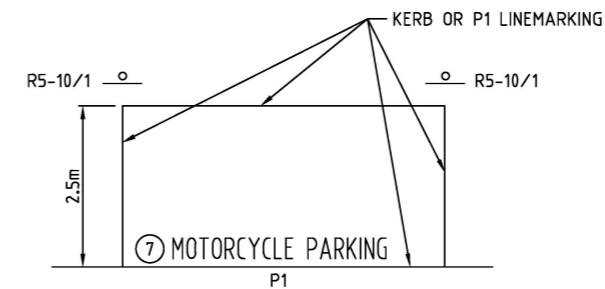

LETTERING - 300 HIGH IN WHITE (PAINT)
NOTE: INDIVIDUAL BAY LINES SHOULD NOT BE MARKED

MOTORCYCLE PARKING MARKING

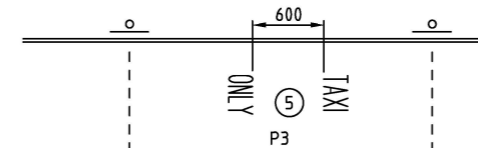

LETTERING - 300 HIGH IN YELLOW (LLM)

TAXI RANK MARKING

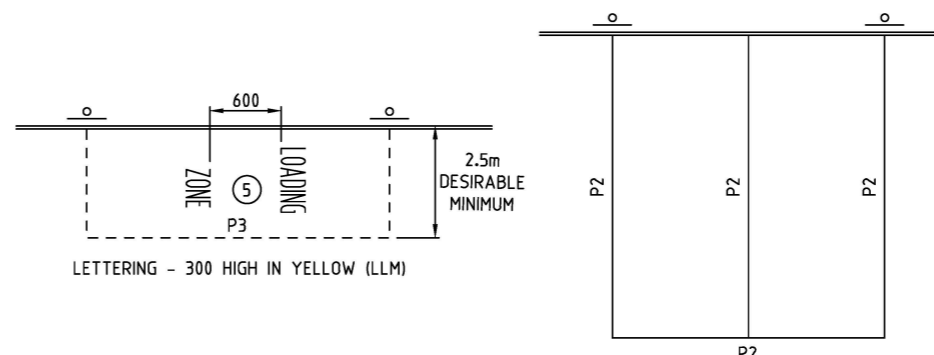

LOADING ZONE / PERMIT ZONE MARKING

NOTES:

- ① CORE ASPHALTIC CONCRETE PAVEMENT AND INSTALL APPROVED SLEEVED 1.3m(-0/+0.05) EXPOSED HEIGHT, 76.1 OD STEEL BOLLARD. THE BOLLARD SHALL BE POWDER COATED 'HAZARD' YELLOW. THE CONTRACTOR SHALL APPLY CLASS 400 REFLECTIVE TAPE TO THE FULL BOLLARD CIRCUMFERENCE - 100mm DEEP BAND OF WHITE TAPE ABOVE 100mm DEEP BAND OF RED TAPE. APPLY 100mm DEEP BAND OF WHITE TAPE BELOW RED TAPE.
- ② APPLY 200mm WIDE YELLOW PAINTED CHEVRONS WITH 300mm GAP BETWEEN BARS.
- ③ APPLY AN APPROVED NON SLIP AGGREGATE AND GLASS BEAD MIX TO CHEVRON AND ACCESS SYMBOL MARKINGS.
- ④ CHEVRONS AND ACCESS SYMBOL MARKINGS SHALL BE IN ACCORDANCE WITH AS2890.6 (CURRENT EDITION).
- ⑤ UNLESS APPROVED OTHERWISE ALL LETTERING SHALL BE IN ACCORDANCE WITH AS1742.2
- ⑥ ANGLED ACCESSIBLE PARKING BAYS SHOULD BE AVOIDED, BUT WHEN NECESSARY SHALL BE DESIGNED TO THE APPROVAL OF THE ROAD AUTHORITY.
- ⑦ PAVEMENT MESSAGE MAY BE MARKED IN MULTIPLE LINES OF TEXT WHERE SPACE IS LIMITED.
FOR EXAMPLE: MOTORCYCLE OR MOTOR CYCLE PARKING
- ⑧ MOTORCYCLE SPACES SHOULD BE LOCATED IN AREAS OF GENTLE GRADES IN BOTH DIRECTIONS.
- ⑨ ALL DIMENSIONS SHOWN ARE IN mm UNLESS SHOWN OTHERWISE.
- ⑩ REFER TO AS2890.1 AND 2890.5 FOR PARKING SPACE DIMENSIONS

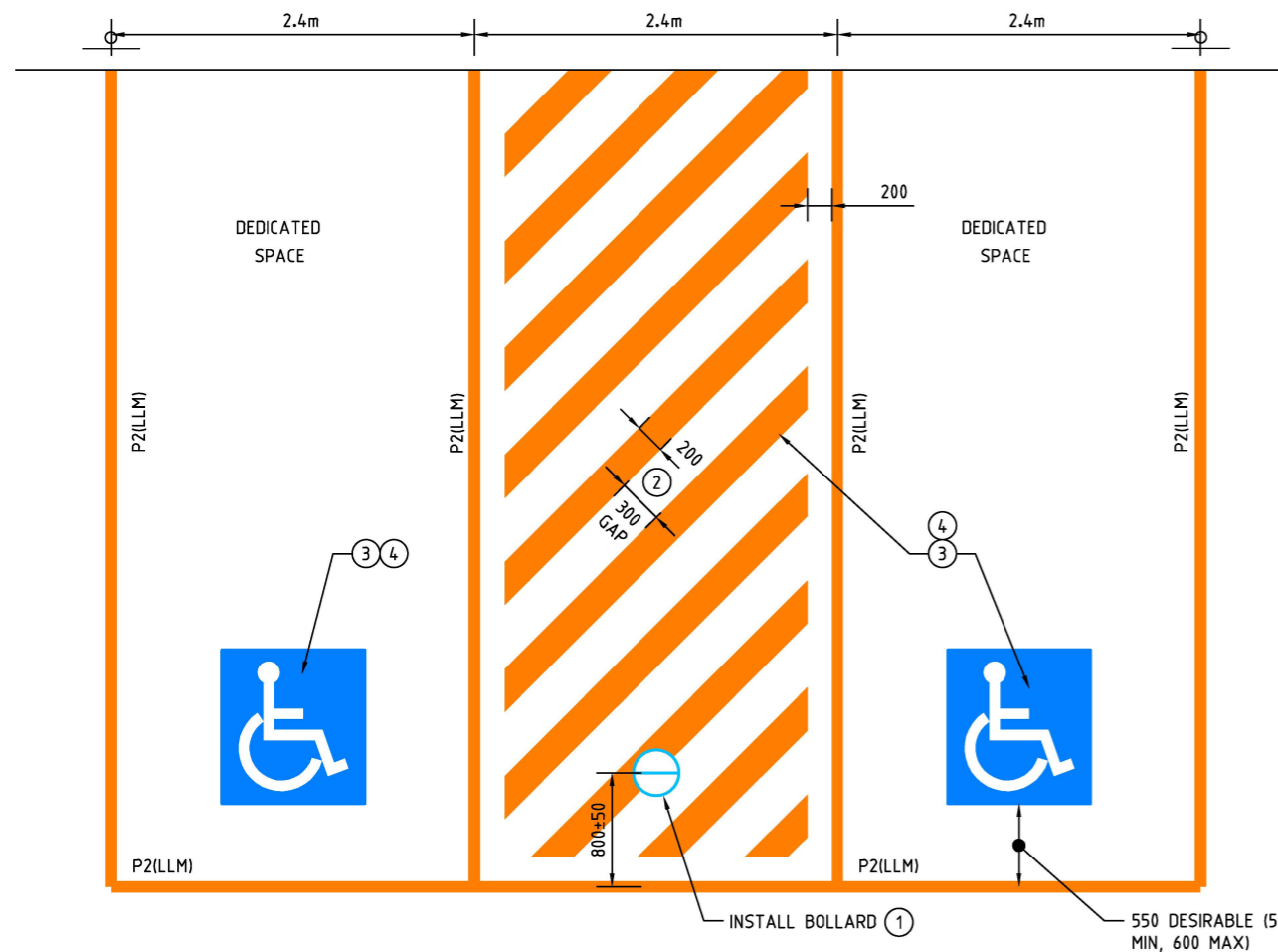

TYPICAL ARRANGEMENT 90 PARKING

(FOR ANGLED ACCESSIBLE PARKING BAYS REFER ⑥)

<p>ACT Government</p> <p>STANDARD DRAWING</p>		
<p>PAVEMENT MARKINGS</p> <p>PARKING</p>		
<p>Authorised: <i>[Signature]</i></p>		
<p>Latest Revision Details</p>		
0	BASED ON DRG DS9-03	19-12-18
Rev	Amendment	Date
<p>Drawing No. ACTSD-3511</p>		<p>Revision 0</p>