

ELEVATION
1:25

8mm PLATE FIN TO TOP. ATTACH TO FRAME BY 100 ON 100 OFF STITCH WELD CONTINUOUS BODY FILL BEFORE PAINTING TO HIDE WELDS

FABRICATE FRAME FROM 75 SHS 3.0 DURAGAL

FRAME TO EXCEED SIGN FACE DIMENSIONS BY 10mm ON ALL SIDES

VANDAL PROOF 'SNAKE EYES' STAINLESS 10x16x30MM (#10,1-1/4") SCREWS AT 300 C/C. PAINT HEADS TO MATCH PANEL COLOUR. SCREWS RECESSED INTO PANEL SO HEAD IS FLUSH WITH SURFACE. ALL HOLES AND RECESSES TO BE MADE PRIOR TO PAINTING.

FINISH FOOTINGS 100 BELOW GROUND LEVEL IN ALL LOCATIONS.

GRASSED AREAS ONLY - CONSTRUCT 100mm THICK 20MPa CONCRETE MOWING STRIP (SHOWN THIS VIEW)

REFER DETAIL THIS SHEET

FOOTING 300 DIA x 600 DEEP (MIN) 20 MPa CONCRETE INTO UNDISTURBED NATURAL GROUND

10mm DIA GALV LOCKING PIN

SIGNS ARE TO BE INSTALLED TRUE AND PLUMB WITH POSTS VERTICAL AND SIGN FACES HORIZONTAL AND SQUARE.

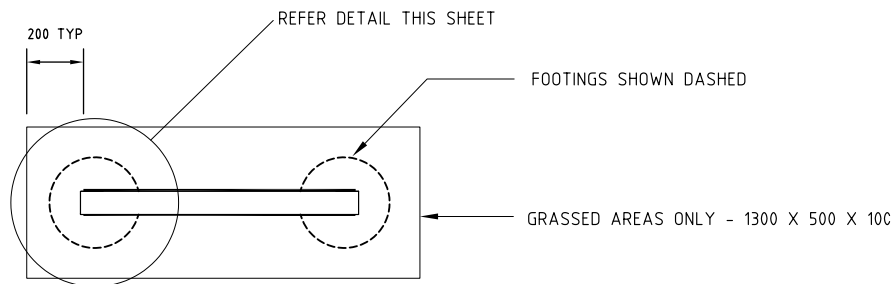

PLAN
1:25

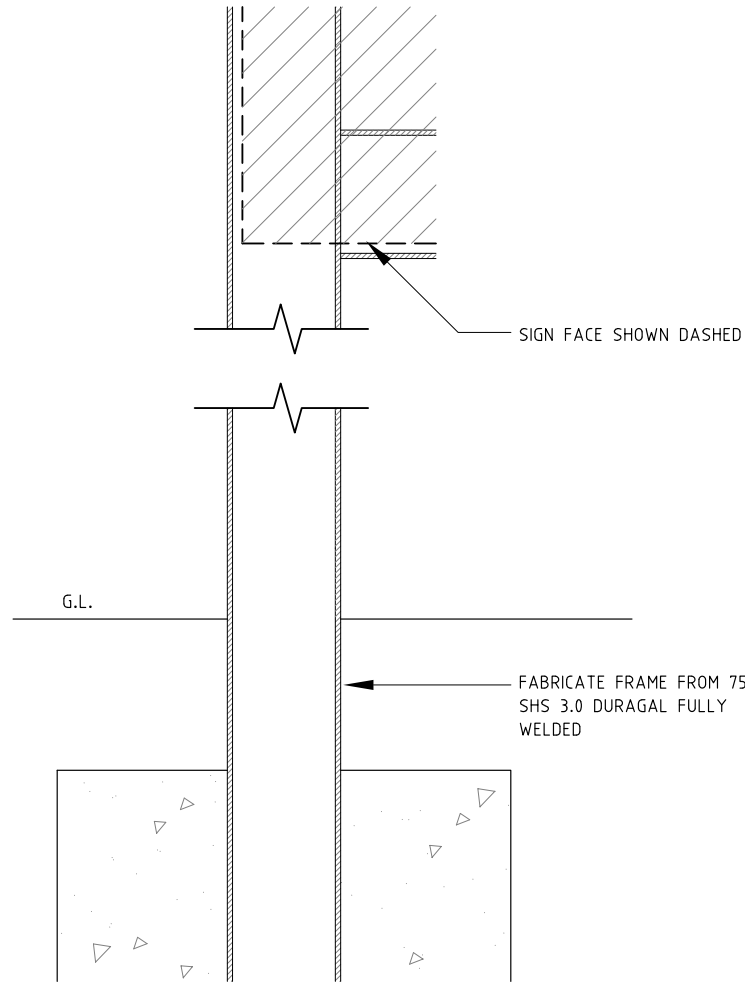

DETAIL SECTION 1:5

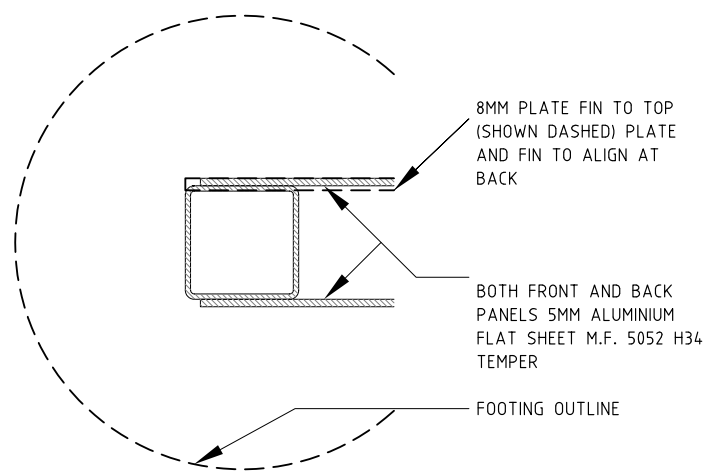

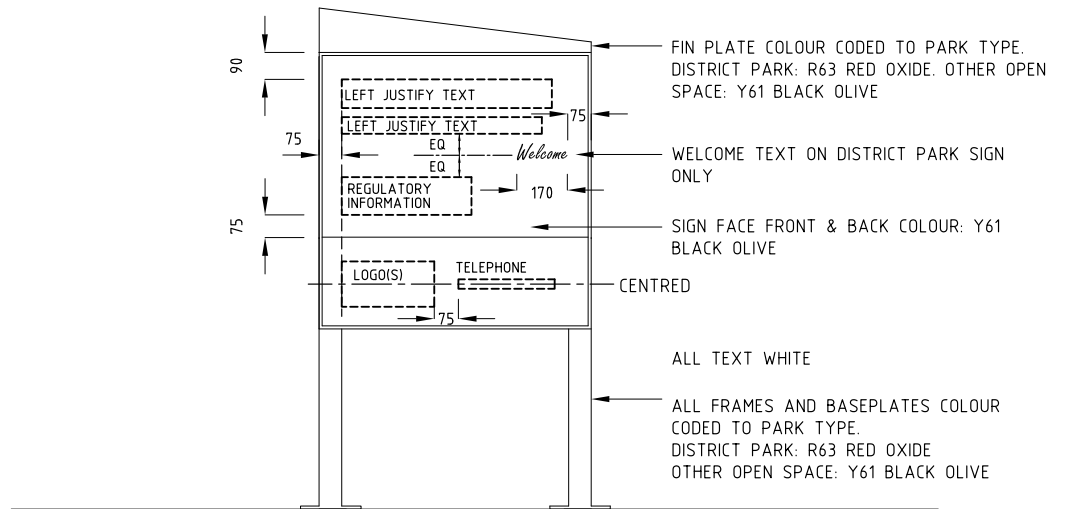

DETAIL PLAN 1:5



FINISHES & TYPICAL GRAPHIC LAYOUT
1:25

NOTES:

- ALL WORK AND MATERIALS ARE TO COMPLY WITH THE LATEST RELEVANT AUSTRALIAN STANDARDS AND CODES.
- GRAPHICS, TEXT & LOGOS TO PROJECT REQUIREMENTS AND ACT GOVERNMENT BRANDING POLICY AT TIME OF INSTALLATION. REFER MIS 22 FOR GRAPHIC GUIDELINES.
- GRIND WELDS SMOOTH AND REMOVE WELD SPATTER. MAKE SMOOTH ALL SHARP OR HAZARDOUS EDGES. COLD GALVANISE PAINT ALL AREAS DISTURBED PRIOR TO PAINT FINISH APPLICATION.
- FOR GALVANISED SURFACES SURFACE PREPARATION MAY INVOLVE DEGREASING, SOLVENT CLEANING AND ETCHING OR LIGHT BRUSH BLASTING. FINISHED SURFACES ARE TO BE SMOOTH AND FLAT WITH PAINT EVENLY APPLIED.
- PAINT FINISH SHALL BE EQUAL TO DE BEER COLOUR SYSTEMS BERTHANE FLEET SERIES 700 - HIGH GLOSS, NON-YELLOWING, 2-PACK POLYURETHANE FINISH (AIR-DRYING OR FORCE-DRYING). INCLUDE SURFACE PREPARATION, EDGE PRIMER, UNDERCOAT PRIMER, 2 SATIN FINISH FINISHING COATS OF PAINT AND 2 HEAVY FINISHING COATS OF CLEAR TWO PACK POLYURETHANE.
- SIGN MESSAGES, GRAPHICS AND PICTOGRAMS MASKED AND SPRAYED ON PAINTED SIGN FACES. ALL GRAPHICS TO BE PERMANENTLY APPLIED AND ACCURATELY REPRODUCED FROM ELECTRONIC FILES.
- TREAT ALL EXPOSED SURFACES WITH APPROVED SACRIFICIAL, INVISIBLE ANTI GRAFFITI TREATMENT SUCH AS PSS 20 OR EQUAL.

 ACT Government		
STANDARD DRAWING		
SIGNAGE STANDARD DETAIL SHEET 2		
Authorised: 		
Latest Revision Details		
0	FIRST ISSUE	25-2-19
Rev	Amendment	Date
Drawing No.		Revision
ACTSD-2510		0