

ELEVATION
1:25

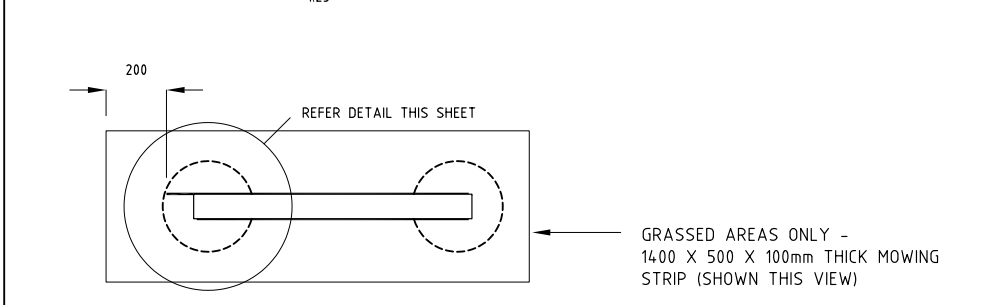

PLAN
1:25

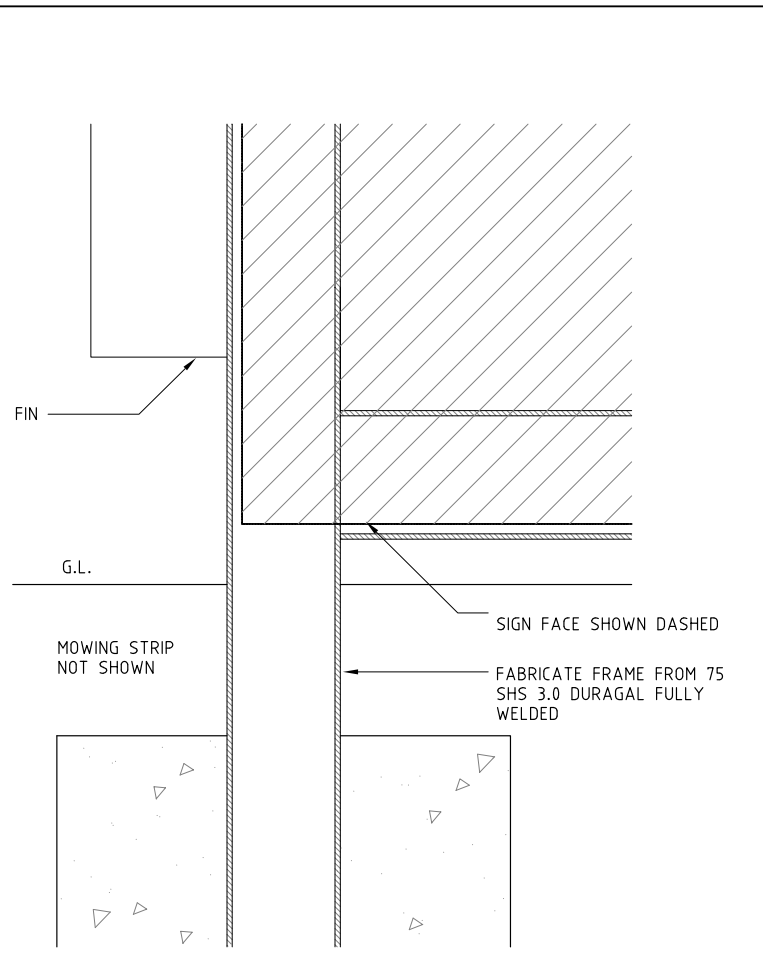

DETAIL SECTION 1:5

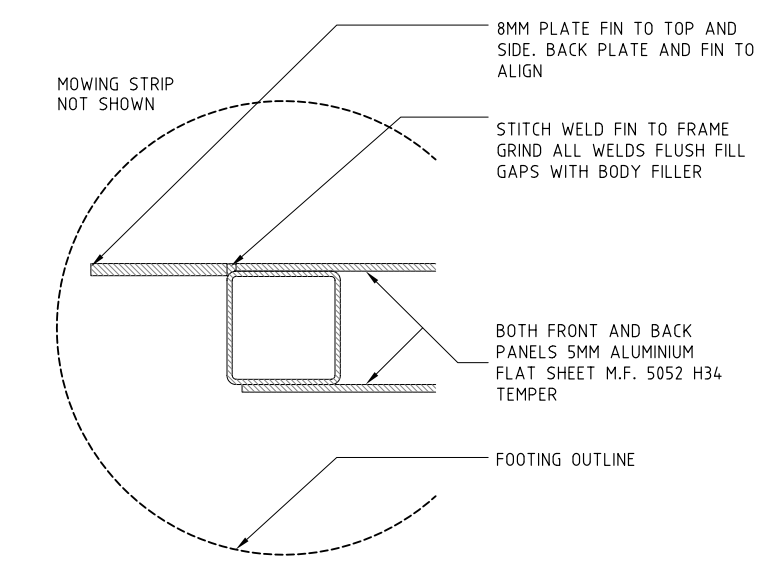

DETAIL PLAN 1:5

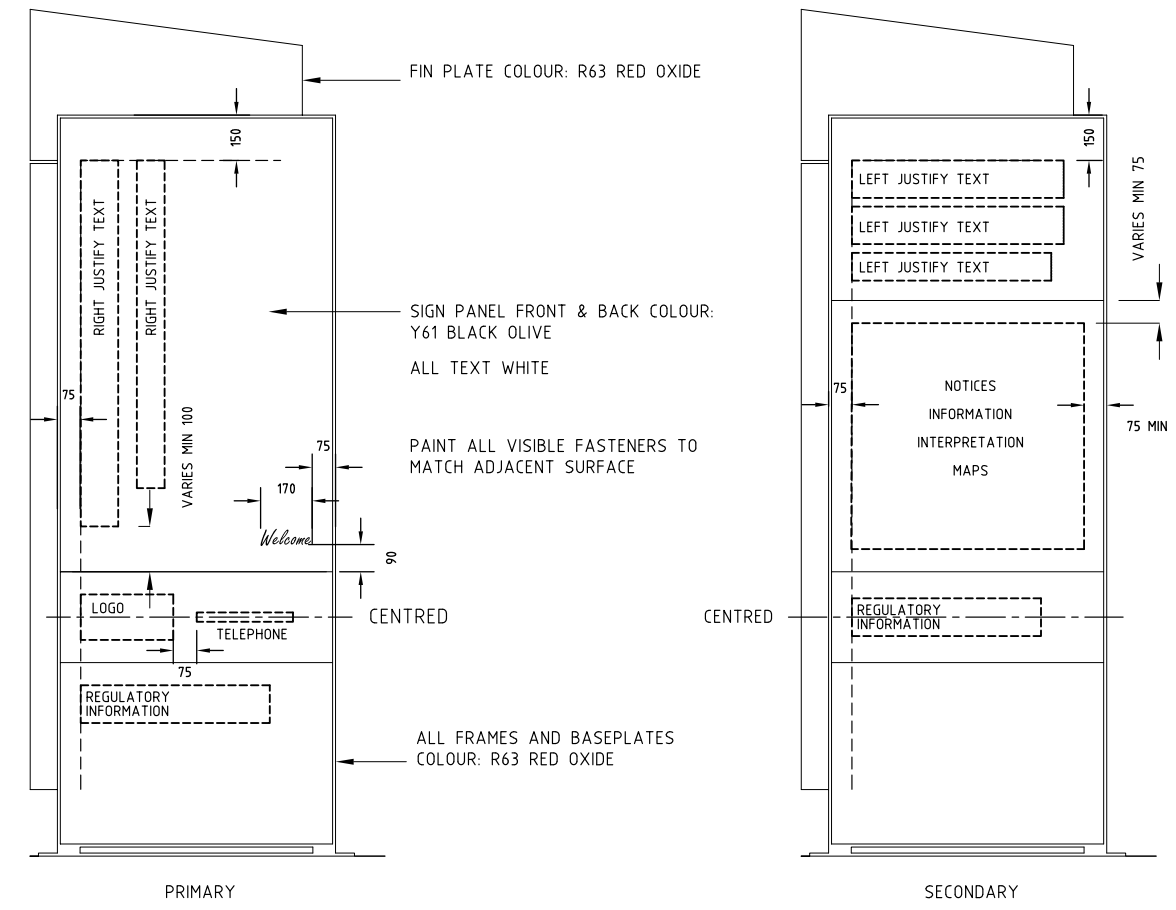

FINISHES & TYPICAL GRAPHIC LAYOUT
1:25

NOTES:

1. ALL WORK AND MATERIALS ARE TO COMPLY WITH THE LATEST RELEVANT AUSTRALIAN STANDARDS AND CODES.
2. GRAPHICS, TEXT & LOGOS TO PROJECT REQUIREMENTS AND ACT GOVERNMENT BRANDING POLICY AT TIME OF INSTALLATION. REFER MIS 22 FOR GRAPHIC GUIDELINES.
3. GRIND WELDS SMOOTH AND REMOVE WELD SPATTER. MAKE SMOOTH ALL SHARP OR HAZARDOUS EDGES. COLD GALVANISE PAINT ALL AREAS DISTURBED PRIOR TO PAINT FINISH APPLICATION.
4. FOR GALVANISED SURFACES SURFACE PREPARATION MAY INVOLVE DEGREASING, SOLVENT CLEANING AND ETCHING OR LIGHT BRUSH BLASTING. FINISHED SURFACES ARE TO BE SMOOTH AND FLAT WITH PAINT EVENLY APPLIED.
5. PAINT FINISH SHALL BE EQUAL TO DE BEER COLOUR SYSTEMS BERTHANE FLEET SERIES 700 - HIGH GLOSS, NON-YELLOWING, 2-PACK POLYURETHANE FINISH (AIR-DRYING OR FORCE-DRYING). INCLUDE SURFACE PREPARATION, EDGE PRIMER, UNDERCOAT PRIMER, 2 SATIN FINISH FINISHING COATS OF PAINT AND 2 HEAVY FINISHING COATS OF CLEAR TWO PACK POLYURETHANE.
6. SIGN MESSAGES, GRAPHICS AND PICTOGRAMS MASKED AND SPRAYED ON PAINTED SIGN FACES. ALL GRAPHICS TO BE PERMANENTLY APPLIED AND ACCURATELY REPRODUCED FROM ELECTRONIC FILES.
7. TREAT ALL EXPOSED SURFACES WITH APPROVED SACRIFICIAL, INVISIBLE ANTI GRAFFITI TREATMENT SUCH AS PSS 20 OR EQUAL.



ACT Government

STANDARD DRAWING

SIGNAGE STANDARD DETAIL SHEET 1

Authorised: 

Latest Revision Details

Rev	Amendment	Date
0	FIRST ISSUE	25-2-19

Drawing No. **ACTSD-2509** Revision **0**