

ABSOLUTE MINIMUM WIDTH ⑤
 DESIGNER SHALL SEEK ROAD
 AUTHORITY APPROVAL

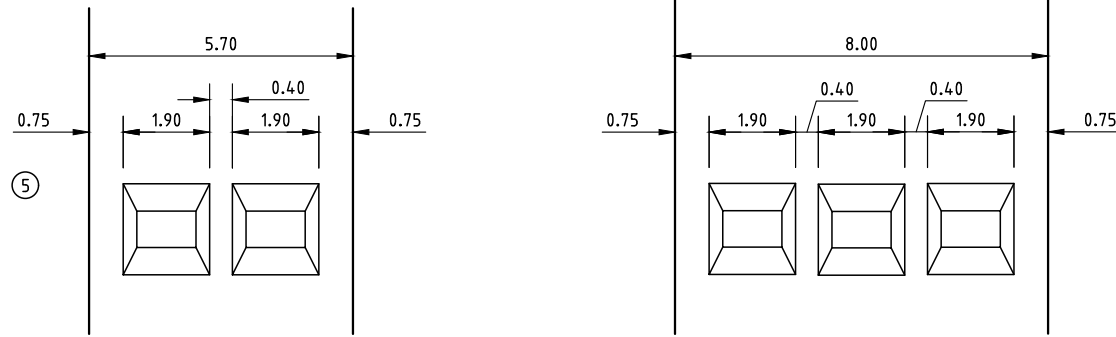

DESIRABLE GAP WIDTHS

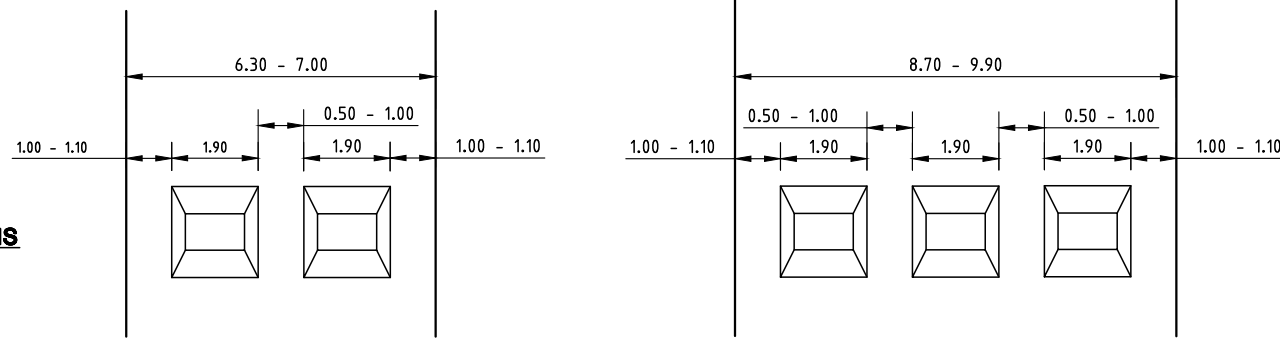

**ALTERNATIVE OPTIONS TO
 ACCOMMODATE DESIRABLE
 GAP WIDTHS** ⑤
 DESIGNER SHALL SEEK ROAD
 AUTHORITY APPROVAL

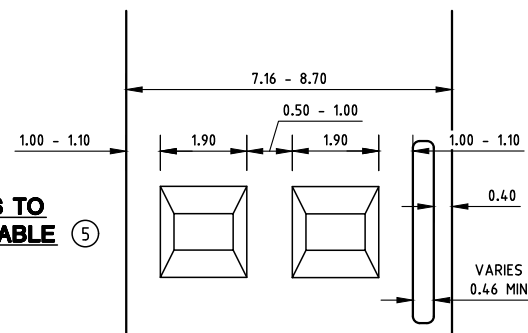

BLISTER ISLAND ⑧

BLISTER ISLAND TREATMENTS MAY VARY BASED ON WIDTH OF ROAD AND SHOULD CONSIDER CYCLE BYPASS WHERE POSSIBLE. ISLAND LOCATION MAY VARY TO SUIT THE EXISTING ROAD GEOMETRY.

WIDE CARRIAGEWAYS

LIAISE WITH THE ROAD AUTHORITY FOR ROADS THAT REQUIRE CUSHIONS >1.9m WIDE

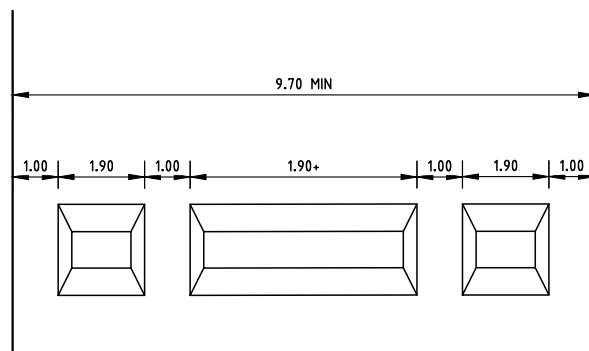

NOTES

- 1 ALL DIMENSIONS ARE IN METRES UNLESS SPECIFIED OTHERWISE.
- 2 THESE ARRANGEMENTS SHOWN ARE A GUIDE ONLY. DESIGNERS SHALL PREPARE DESIGN DETAILS TO SUIT LOCAL CONDITIONS AS APPROPRIATE AND OBTAIN APPROVAL FROM THE ROAD AUTHORITY.
- 3 THE DESIGNER IS REQUIRED TO DEVELOP A LAYOUT DESIGN FOR ROAD CUSHIONS WHICH PREVENTS VEHICLES FROM BYPASSING THE HUMPS, DOES NOT ENCOURAGE MOTORISTS TO DEVIATE FROM THE TRAFFIC LANE TO BYPASS THE HUMPS, AND HAS SAFE GAP WIDTHS TO ENABLE CYCLISTS TO SAFELY BYPASS THE HUMPS.
- 4 GAPS BETWEEN ROAD CUSHIONS SHALL BE OMITTED IF NOT ON AN EXISTING OR KNOWN FUTURE BUS ROUTE AND NOT REQUIRED FOR DRAINAGE OR TO THE ROAD AUTHORITIES DIRECTION.
- ⑤ THE DESIGNER SHALL SEEK TO ADOPT DESIRABLE GAP WIDTHS WHERE PRACTICAL. WHERE DESIRABLE GAP WIDTHS CANNOT BE ACHIEVED, AND/OR WHERE THE USE OF BLISTER ISLANDS OR A WIDE CENTRE CUSHION IS REQUIRED TO ACHIEVE DESIRABLE GAP WIDTHS, THE DESIGNER SHALL SEEK APPROVAL FROM THE ROAD AUTHORITY.
- 6 IT IS DESIRABLE THAT ROAD CUSHIONS BE PLACED IN LINE WITH THE PARKING BAY LINES WHERE PARALLEL PARKING IS PERMITTED.
- 7 THE DESIGNER SHALL PLACE ROAD CUSHIONS IN LOCATIONS THAT CONSIDER DRIVEWAY TURNING MOVEMENTS.
- ⑧ BLISTER ISLANDS SHALL BE APPROPRIATELY LINEMARKED (E.G. CHEVRONS, WHITE GORE, LANE LINES IN LLM) TO GUIDE ROAD USERS AWAY FROM THE BLISTER ISLAND. THE BLISTER ISLAND SHALL BE APPROPRIATELY LIT TO THE ROAD CATEGORY. CONSIDER POTENTIAL FOR BLOCKAGE OF SPACE BETWEEN BLISTER ISLAND AND KERBS DUE TO TREE LEAF/BRANCH LITTER. THE DESIGNER SHALL SEEK APPROVAL WITH THE ROAD AUTHORITY IN CASES WHERE BLISTER ISLANDS ARE PROPOSED.

**ASPHALTIC CONCRETE
 ROAD CUSHION
 LAYOUT OPTIONS**

Authorised: 

Latest Revision Details

Rev	Amendment	Date
0	FIRST ISSUE	02-06-26

Drawing No. **ACTSD-3534b** Revision **0**