



ACT
Government

Transport Canberra and
City Services

FREEDOM OF INFORMATION COVERSHEET

The following information is provided pursuant to section 28 of the *Freedom of Information Act 2016*.

FOI reference: TCCSFOI 2018-011

Information to be published	Status
1. Access application	Published
2. Decision notice and schedule	Published
3. Documents	Published with redactions
4. Additional information identified	No
5. Fees	n/a
6. Processing time (In working days)	31 days (extension granted)
7. Decision made by Ombudsman	n/a
8. Additional information identified by Ombudsman	n/a
9. Decision made by ACAT	n/a
10. Additional information identified by ACAT	n/a

Ref: 18-012

Recid TCCS 30/1/18

Ireland-Bell, Bronwyn

From: Leonard, Matt on behalf of CMTEDD FOI
Sent: Tuesday, 30 January 2018 11:30 AM
To: TCCS_FreedomOfInformation
Subject: FW: Freedom of Information request [SEC=UNCLASSIFIED, DLM=For-Official-Use-Only]

Hi team,

Can you please confirm that you accept transfer of this request? Please note that the address mentioned in the request is not in Gordon but in Banks.

Cheers

Matt Leonard | Freedom of Information Coordinator | Reporting and Information Management
Ph: 02 6207 3417
Corporate | Chief Minister, Treasury and Economic Development Directorate | ACT Government
Level 2, Canberra Nara Centre | GPO Box 158 Canberra ACT 2601 | www.act.gov.au

From: [REDACTED]
Sent: Friday, 26 January 2018 8:06 PM
To: CMTEDD FOI <CMTEDDFOI@act.gov.au>
Subject: Freedom of Information request

Please find online enquiry details below. Please ensure this enquiry is responded to within fourteen working days.

Your details

All fields are optional, however an email address OR full postal address must be provided for us to process your request. An email address and telephone contact number will assist us to contact you quickly if we need to discuss your request.

Title: Mr
First Name: [REDACTED]
Last Name: [REDACTED]
Business/Organisation:
Address: [REDACTED]
Suburb: [REDACTED]
Postcode: [REDACTED]
State/Territory: ACT
Phone/mobile: [REDACTED]
Email address: [REDACTED]

Request for information

(Please provide as much detail as possible, for example subject matter and relevant dates, and also provide details of documents that you are not interested in.)

Under the Freedom of Information Act 2016 I want to access the following document/s (*required field): Please provide copies of all correspondence, approvals and or applications regarding the installation of fencing/restrictions on the nature strip in front, adjacent or adjoining to house number [REDACTED] [REDACTED] Gordon ACT 2906. Fencing was installed in 2013, and numerous

complaints have been made to ACT Government services regarding them since then.

I do not want to access the following documents in relation to my request::

Thank you.
Freedom of Information Coordinator



ACT
Government

Transport Canberra and
City Services

Mr [REDACTED]
[REDACTED]

Dear Mr [REDACTED]

Freedom of information request: Reference 18-011

I refer to your application made under the *Freedom of Information Act 2016* (the FOI Act) received by the Transport Canberra and City Services (TCCS) directorate on 30 January 2018, in which you sought access to:

- all correspondence, approvals and or applications regarding the installation of fencing/restrictions on nature strip in front, adjacent or adjoining to house number [REDACTED] in Gordon.

I am an Information Officer appointed by the Director-General under section 18 of the Act to deal with access applications made under Part 5 of the Act.

I understand that you have agreed to an extension for TCCS to provide a decision on your access application by 14 March 2018.

Decision on access

A search of TCCS records was conducted and 20 documents (43 pages) were identified that fall within the scope of your request.

I have included as Attachment A to this decision the schedule of relevant documents. This provides a description of each document that falls within the scope of your request and the access decision for each of those documents.

Documents identified as relevant to your request contain information that I consider to be, on balance, contrary to the public interest to disclose under the test set out in section 17 of the Act. The information considered contrary to the public interest to disclose includes the name, contact details and personal information of third parties.

I have considered the following material in the assessment of these documents:

- the FOI Act, in particular:
 - Schedule 2 (b)(i) – the person making the request
- the *Information Privacy Act 2014*; and
- the content of the documents that fall within the scope your request.

As documents referenced numbers 1-10, 13-17 and 19-20 contains information of third parties, I have decided to grant access, under section 50 of the Act, to these

documents (Attachment B) with deletions applied to information that I consider would be contrary to the public interest to disclose.

Disclosure of personal information is governed by the 'use and disclosure' privacy principles. Part 3 of the *Information Privacy Act 2014* (TTP 6.1) states that an agency that holds personal information about an individual that has been collected for a particular purpose, must not disclose the information to a third party unless the individual has consented to the use or disclosure of the information. I have, therefore, decided that it is not in the public interest to disclose information that is considered to be personal information.

Charges

No fee is payable as the number of pages being released is within the fee-free threshold.

Online publishing – disclosure log

Under section 28 of the Act, TCCS maintains an online record of access applications called a disclosure log. Your original access application, my decision and documents released in response to your access application will be published in the TCCS disclosure log from 3 days after the date of this decision. Your personal details will not be published.

You may view TCCS' disclosure log at www.tccs.act.gov.au/about-us/freedom_of_information.

Ombudsman review

My decision on your access request is a reviewable decision as identified in Schedule 3 of the Act. You have the right to seek Ombudsman review of this outcome under section 73 of the Act within 20 working days from the day that my decision is published in TCCS' disclosure log or a longer period allowed by the Ombudsman.

If you wish to request a review of my decision, you may write to the Ombudsman at:

The ACT Ombudsman
GPO Box 442
CANBERRA ACT 2601

Via email: ombudsman@ombudsman.gov.au

ACT Civil and Administrative Tribunal (ACAT) review

Under section 84 of the Act, if a decision is made under section 82(1) on an Ombudsman review, you may apply to the ACAT for review of the Ombudsman decision.

Further information may be obtained from ACAT at:

ACT Civil and Administrative Tribunal

Level 4, 1 Moore Street

GPO Box 370

CANBERRA CITY ACT 2601

Telephone: (02) 6207 1740

www.acat.act.gov.au

If you have any questions concerning the Directorate's processing of your request, or would like further information, please contact the Directorate's FOI Coordinator on 6205 5408 or email tccs.foi@act.gov.au.

Yours sincerely



Cherie Hughes

Information Officer

Transport Canberra and City Services

14 March 2018



FREEDOM OF INFORMATION SCHEDULE

PLEASE BE AWARE THAT UNDER THE FREEDOM OF INFORMATION ACT 2016, SOME OF THE INFORMATION PROVIDED TO YOU WILL BE RELEASED TO THE PUBLIC THROUGH THE ACT GOVERNMENT'S OPEN ACCESS SCHEME. THE OPEN ACCESS RELEASE STATUS COLUMN OF THE TABLE BELOW INDICATES WHAT DOCUMENTS ARE INTENDED FOR RELEASE ONLINE THROUGH OPEN ACCESS.

PERSONAL INFORMATION OR BUSINESS AFFAIRS INFORMATION WILL NOT BE MADE AVAILABLE UNDER THIS POLICY. IF YOU THINK THE CONTENT OF YOUR REQUEST WOULD CONTAIN SUCH INFORMATION, PLEASE INFORM THE CONTACT OFFICER IMMEDIATELY.

INFORMATION ABOUT WHAT IS PUBLISHED ON OPEN ACCESS IS AVAILABLE ONLINE AT: [HTTP://WWW.TCCS-ACT.GOV.AU/ABOUT-US/FREEDOM_OF_INFORMATION](http://www.tccs.act.gov.au/about-us/freedom_of_information)

REFERENCE NO	WHAT ARE THE PARAMETERS OF THE REQUEST
TCCS FOI 2018-011	NATURESTRIP APPROVAL

REF NO	PAGE NUMBER	DESCRIPTION	DATE	STATUS	REASON FOR NON-RELEASE OR DEFERRAL	OPEN ACCESS RELEASE STATUS
1	1	ENQUIRY – 180126-00484	31 JANUARY 2018	PARTIAL ACCESS	INFORMATION PRIVACY ACT 2014	PARTIAL ACCESS
2	2	NOTIFICATION NO - 751904	25 JANUARY 2013	PARTIAL ACCESS	INFORMATION PRIVACY ACT 2014	PARTIAL ACCESS
3	3-5	INCIDENT REFERENCE NO – 131126-002300	26 NOVEMBER 2013	PARTIAL ACCESS	INFORMATION PRIVACY ACT 2014	PARTIAL ACCESS
4	6	NOTIFICATION NO – 762243	21 MARCH 2013	PARTIAL ACCESS	INFORMATION PRIVACY ACT 2014	PARTIAL ACCESS
5	7-9	EMAIL	7 FEBRUARY 2013	PARTIAL ACCESS	INFORMATION PRIVACY ACT 2014	PARTIAL ACCESS
6	10	EMAIL	1 FEBRUARY 2013	PARTIAL ACCESS	INFORMATION PRIVACY ACT 2014	PARTIAL ACCESS

7	11-13	EMAIL	16 JANUARY	PARTIAL ACCESS	INFORMATION PRIVACY ACT 2014	PARTIAL ACCESS
8	14	EMAIL	6 FEBRUARY 2013	PARTIAL ACCESS	INFORMATION PRIVACY ACT 2014	PARTIAL ACCESS
9	15	APPLICATION TO UNDERTAKE NATURE STRIP DEVELOPMENT	10 DECEMBER 2012	PARTIAL ACCESS	INFORMATION PRIVACY ACT 2014	PARTIAL ACCESS
10	16-18	LETTER - NATURE STRIP DEVELOPMENT APPLICATION	9 DECEMBER 2012	PARTIAL ACCESS	INFORMATION PRIVACY ACT 2014	PARTIAL ACCESS
11	19	EMAIL - PERMIT 465	10 DECEMBER 2012	FULL ACCESS		FULL ACCESS
12	20	EMAIL	18 DECEMBER 2012	FULL ACCESS		FULL ACCESS
13	21	APPLICATION TO UNDERTAKE NATURE STRIP DEVELOPMENT	10 DECEMBER 2012	PARTIAL ACCESS	INFORMATION PRIVACY ACT 2014	PARTIAL ACCESS
14	22-25	NATURE STRIP DEVELOPMENT APPLICATION - 465	9 DECEMBER 2012	PARTIAL ACCESS	INFORMATION PRIVACY ACT 2014	PARTIAL ACCESS
15	26-28	EMAIL	14 JANUARY 2012	PARTIAL ACCESS	INFORMATION PRIVACY ACT 2014	PARTIAL ACCESS
16	29-31	EMAIL	10 APRIL 2012	PARTIAL ACCESS	INFORMATION PRIVACY ACT 2014	PARTIAL ACCESS
17	32-33	EMAIL	10 APRIL 2012	PARTIAL ACCESS	INFORMATION PRIVACY ACT 2014	PARTIAL ACCESS

18	34-39	PICTURES (ATTACHMENT TO DOCUMENT 17)			FULL ACCESS		
19	40-42	EMAIL	10 APRIL		PARTIAL ACCESS	INFORMATION PRIVACY ACT 2014	PARTIAL ACCESS
20	43	REF NO - 180126-000484 REF NO - 131126- 002300	26 JANUARY 2018 26 NOVEMBER 2011		PARTIAL ACCESS	INFORMATION PRIVACY ACT 2014	PARTIAL ACCESS

01/02/2018

Inspecting Ranger: Andrew Melville **Date Created:** 31/01/2018 01.02 PM**Investigation ID:** 1562 **Reference No:** 180126-000484**Item Type:** Nature Strips **Sign Type:****Retailer:** No Value**Owner Name:****Owner Phone:****Vehicle Description:****Owner Address:****Item Location:** [REDACTED]**Item Suburb:** Banks**Item Description:****Customer Complaint:** The nature strip in front of # [REDACTED] Banks has been fenced off by a private individual, and is overgrown with weeds and empty garden beds. It is a hideous eyesore.**Impound Item Value:** No Value**Impound Start:** No Value**Impound Request:** No Value**MVR Check Date:** No Value**Rego Expiry:** No Value**Police Check Date:** No Value**Police History Req:** No Value**Police History Re:** No Value**Vehicle Reported:** No Value

Investigation Notes

Date Created: 31/01/2018 03.55 PM**Thread Text:** A check with Land use there is a permit for 15 bollard's and tree plantings at this address**Date Created:** 01/02/2018 02.35 PM**Thread Text:** Attended location the bollard's are placed in accordance with the permit being at least 1200mm apart being treated post between 120 and 200mm diameter and at least 1200mm back from the kerb. There was no long grass affecting LOS or pedestrian access to the area. 12:50 1/2/2018.

NOTIFICATION

Issue No. 751904

Date: 14-DEC-2012

Number of Pages: 1
(including this one)

To: Urban Tree Management (Level 8 Mac House)
Contact Nos.: 6207 6255 (fax)

From: Canberra Connect Municipal Services
Contact Nos.: 13 22 81

Subject: Request for Services
Trees - Street (Single)
Request for Information

Caller's [REDACTED]
(H) (B) (MOB)

Location: BANKS, [REDACTED] BANKS

Details: NS DEVELOPMENT APPLICATION - INCLUDES TREE PLANTING AND BOLLARDS TO PREVENT PARKING

Action / Remarks: PROVIDED FEEDBACK TO MATT POTTER THAT I WOULD MAKE CONTACT WITH CONSTITUENTS TO LOOK AT PLANTING REQUEST. 762243 FOR PLANTING

This Issue to be completed/resolved by: 25-JAN-2013

Date Received: 14-DEC-2012

Date Actioned:

Action Taken:

Work has been carried out in accordance with the required specifications

Signed: Supervisor

Signed: Area Manager

Please fill in the details and return to your Area Manager

Territory and Municipal Services • Parks and City Services
Level 8 Macarthur House, 12 Wattle Street, Lyneham, ACT 2602

PO Box 352, Civic Square ACT 2608 • Telephone 13 22 81 • Facsimile: (02) 6207 5366

ACT Government Homepage: www.act.gov.au

Email: PAOS_Ops_Support@act.gov.au



ACT
Government

**Access
Canberra.**

Incident Reference # 131126-002300

Subject: Nature strip development

Date Created: 26/11/2013 03.53 PM

Note By (Craig Allen) (19/12/2013 04.21 PM)

no further action required

Note By (Craig Allen) (19/12/2013 04.20 PM)

attended location sighted bollard's placed on nature strip spoke to owner of property [REDACTED] who produced a permit for the area. Spoke to complainant [REDACTED] and advised him of this

Note By (A.M) (26/11/2013 03.53 PM)

Nature strip has been developed with logs vertical out of ground at bend in road

Additional Incident Details (if available)

Status: Resolved

Category: Naturestrips

Type of Correspondence: Request for Service

Street: [REDACTED]

Suburb: Banks

Postal Code:

Routine: Nature Strips

Reporting party: Member of Public

Priority: Medium

Assigned: Craig Allen

Contact Information

First Name: [REDACTED]

Last Name: [REDACTED]

Phone Number: [REDACTED]

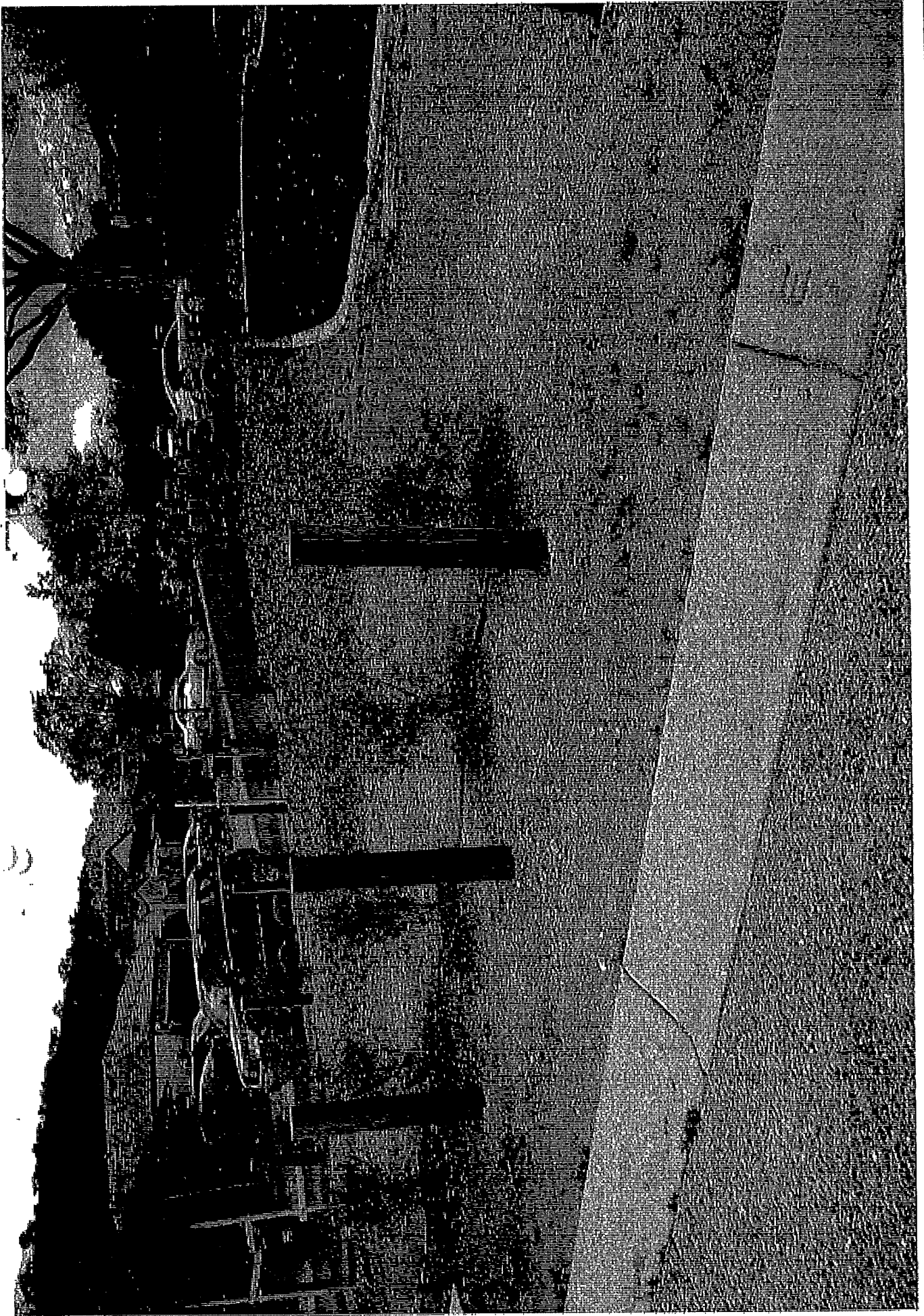

NOTIFICATION

Issue No. 762243

Date:07-FEB-2013

Number of Pages: 1
(including this one)

To: **Urban Tree Management (Level 8 Mac House)**
Contact Nos.: **6207 6255 (fax)**

From: **Canberra Connect Municipal Services**
Contact Nos.: **13 22 81**

Subject: Request for Services
Trees - Street (Single)
Tree Planting Request

Caller's [REDACTED]
(H) (B) (MOB)

Location: **BANKS, [REDACTED] BANKS**
Details: **REQUEST FOR PLANTING FOLLOWING NSDA. (761904)**

Action / Remarks: **5/2 ON SITE WITH [REDACTED] AGREED TO PLANT 2 OR POSSIBLE 3. PISTACIAS IN AUTUMN/WINTER. [REDACTED] AND ADD TO PROGRAM. ENTERED INTO TOUGH BOOK TO PLANT 2 PISTACIAS 8M APART**

This Issue to be completed/resolved by: 21-MAR-2013

Date Received:07-FEB-2013

Date Actioned:

Action Taken:

Work has been carried out in accordance with the required specifications

Signed: Supervisor

Signed: Area Manager

Please fill in the details and return to your Area Manager

Territory and Municipal Services • Parks and City Services
Level 8 Macarthur House, 12 Wattle Street, Lyneham, ACT 2602
PO Box 352, Civic Square ACT 2608 • Telephone 13 22 81 • Facsimile: (02) 6207 5366
ACT Government Homepage: www.act.gov.au

Email: PACS_Ops_Support@act.gov.au

Ireland-Bell, Bronwyn

From: [REDACTED]
Sent: Thursday, 7 February 2013 4:53 PM
To: TCCS LC Public Land Use
Cc: [REDACTED]
Subject: Re: Fwd: Approved Permit 465 NS

Good afternoon [REDACTED]

We would like to thank you for your support. Please pass on our thanks to all parties concerned.

Regards,
[REDACTED]

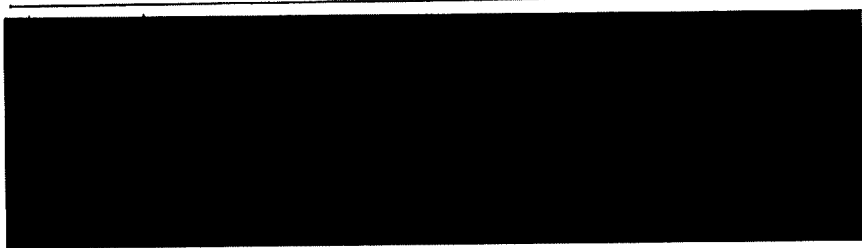

P Please consider the environment before printing this email

[REDACTED] --07/02/2013 04:21:54 PM---Sent from my iPad Begin forwarded message:

From:
[REDACTED]

To:
[REDACTED]

Cc:
[REDACTED]

Date:

07/02/2013 04:21 PM

Subject:

Fwd: Approved Permit 465 NS

Sent from my iPad

Begin forwarded message:

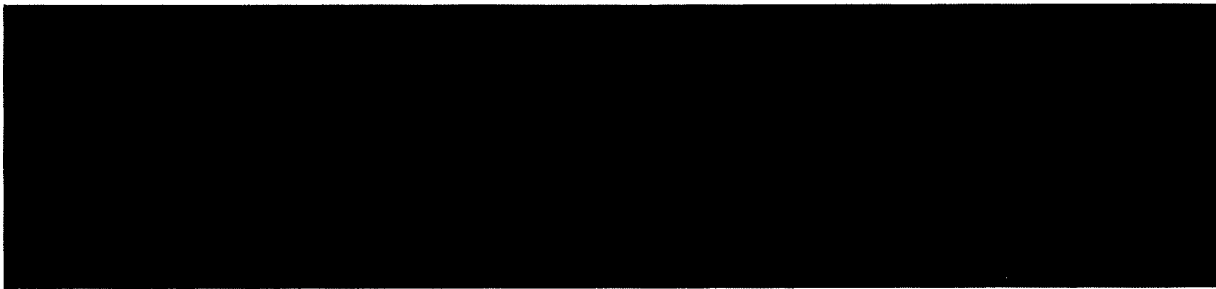

Hi,

Please find attached your approved permit

Regards,

Pam Ellis
Permit Officer

Ph. 02 62058794 | Fax. 02 62072544

Licensing and Compliance, City Services, Parks and City Services | Territory and Municipal Services

Directorate |

ACT Government

Stromlo Office, 500 Cotter Rd, Weston Act 2611 | GPO Box 158 Canberra ACT 2601 | www.act.gov.au

<http://www.act.gov.au/>

This email, and any attachments, may be confidential and also privileged. If you are not the intended recipient, please notify the sender and delete all copies of this transmission along with any attachments immediately. You should not copy or use it for any purpose, nor disclose its contents to any other person.

-----[attachment "20130207155430813.pdf" deleted by

DISCLAIMER - This email and any files transmitted with it are confidential and may contain privileged or copyright information. If you are not the intended recipient you must not copy, distribute or use this email or the information contained in it for any purpose other than to notify us. If you have received this message in error, please notify the sender immediately, and delete this email from your system.

Any views expressed in this message are those of the individual sender, except where the sender specifically states them to be the views of [REDACTED]

Please note that interest rates and/or terms referred to in this email are indicative only, and are subject to change without notice. Full terms and conditions are in our Product Guide. Fees and Charges may be payable, and are set out in our Fees and Charges brochure. Before acquiring and/or renewing a product, you should consider whether it is appropriate for you.

We do not guarantee that this material is free from viruses or any other defects.

Ireland-Bell, Bronwyn

From: Melville, Andrew
Sent: Thursday, 1 February 2018 2:38 PM
To: [REDACTED]
Subject: [REDACTED] [SEC=UNCLASSIFIED]
Attachments: 20180201143856136.pdf

Afternoon [REDACTED]

I Attended [REDACTED] Banks today the bollard's are placed in accordance with the permit being at least 1200mm apart being treated post between 120 and 200mm diameter and at least 1200mm back from the kerb. There was no long grass affecting LOS or pedestrian access to the area. 12:50 1/2/2018. Attached is the job sheet from today's visit.

Cheers

Andrew Melville | City Ranger

Phone 02 62077132 | Fax 02 62077133 | Mobile [REDACTED]

City Presentation | Transport Canberra and City Services | ACT Government

2 Ellmatta Street Reid | GPO Box 158 Canberra ACT 2601

Ireland-Bell, Bronwyn

From: McCarthy, Shelle
 Sent: Wednesday, 16 January 2013 1:49 PM
 To: TCCS_LC Permit Approvals
 Subject: RE: Nature Strip - [REDACTED] Banks

Hi Matt

I have seen the application. The way I read it was that the resident wants us to consider installing bollards and planting some trees to prevent parking on the verge. There is room for us to plant an additional 2 trees which we can do in winter this year as part of our deciduous tree planting program.

I will be back in the office tomorrow and I will pop around to see you.

Shelle

From: Potter, Matt On Behalf Of TAMS, Permit Approvals
 Sent: Wednesday, 16 January 2013 11:22
 To: McCarthy, Shelle
 Subject: Nature Strip - [REDACTED] Banks

Good morning Shelle,

I've moved down to the Public Use Team from Licensing and Compliance for the next three months and have been alerted to an outstanding application/decision.

I've been advised by Matt Badham that you are the appropriate contact in this matter.

Please find attached:

Document xxx7591 – Nature Strip Development application for [REDACTED] Banks.

Document xxx6778 – Application to undertake Nature Strip Development Cover Sheet.

Document xxx3717 – Cover letter for Nature Strip Development from [REDACTED]

Document xxx2694 – Email communication.

The applicant has submitted an application for consideration regarding the use of a nature strip adjacent to his property as 'a car park'.

The area is displayed below:

Could you review and determine if approval is granted from Urban Treescapes?

If you require further information in relation to this or any other licensing matter, please contact me on the below detail.

Kind regards,

Matt Potter | Licensing Officer |

Phone 02 6207 2138 | Fax 02 6207 5956 | Email <mailto:matt.potter@act.gov.au> matt.potter@act.gov.au
<mailto:tams.lc@act.gov.au> tams.lc@act.gov.au

Licensing and Compliance | Territory and Municipal Services Directorate | ACT Government
Level 8, Macarthur House, 12 Wattle Street, Lyneham ACT 2602 | GPO Box 158 Canberra ACT 2601 |
<http://www.act.gov.au/> www.act.gov.au

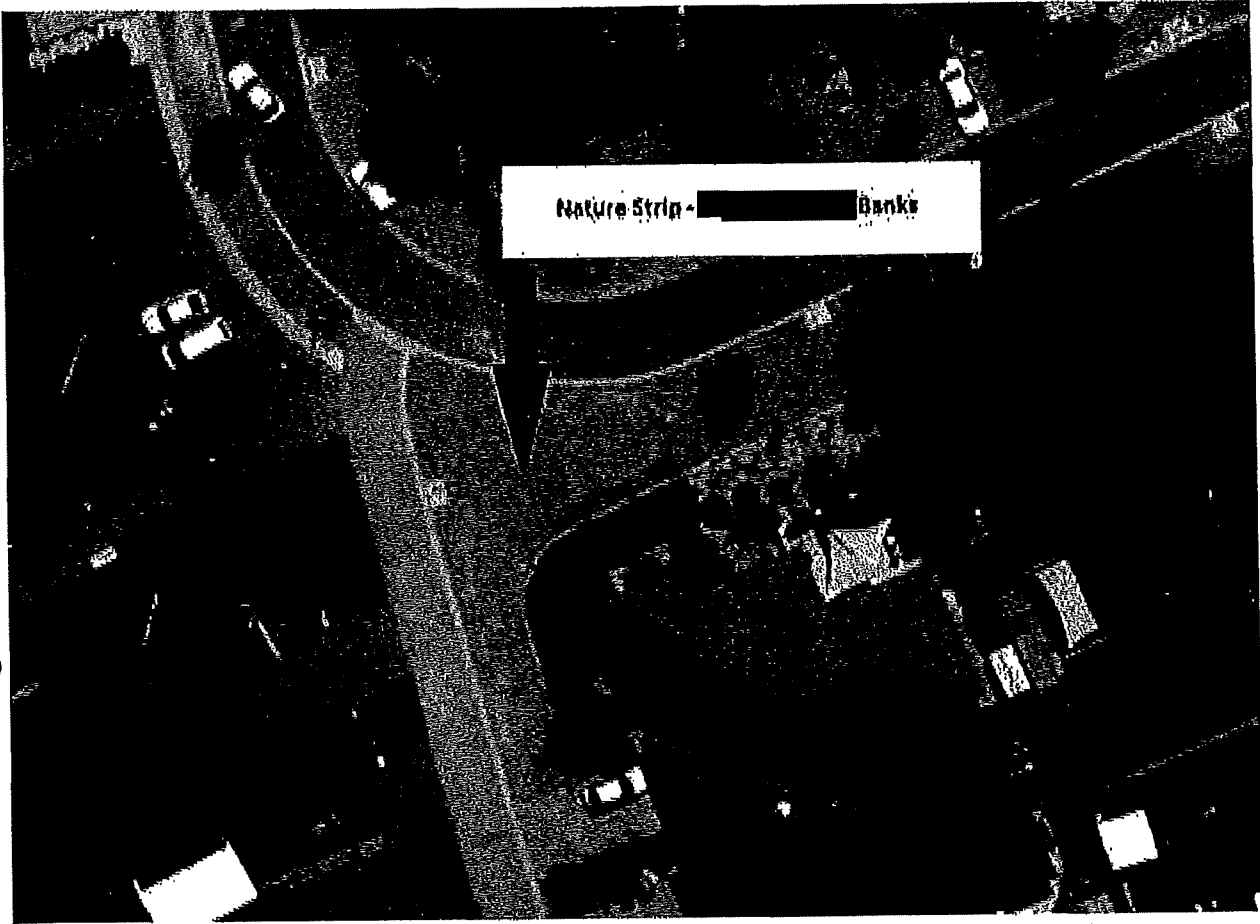

Ellis, Pamela

From: McCarthy, Shelle
Sent: Wednesday, 6 February 2013 9:46 AM
To: TAMS, Permit Approvals
Subject: RE: Permlt_465

Hi Pam

I advised Matt Potter in mid January that I would make contact with the applicant with regard to the planting of trees. I met with [REDACTED] yesterday regarding the planting of 3 additional trees on the verge. Urban Treescapes will carry out this planting during autumn/winter. This is the only component of the application that I am involved with. The parking and the installation of bollards will require input from Place Management.

Shelle

From: Ellis, Pamela **On Behalf Of** TAMS, Permit Approvals
Sent: Wednesday, 6 February 2013 09:21
To: McCarthy, Shelle
Subject: FW: Permlt_465

Hi Shelle

I have spoken to [REDACTED] this morning regarding this application and he advised me that you met with him onsite yesterday

Can you please provide comments for us so we can process/finalise this application please

Thanks so much

Pam Ellis
 Permit Officer
 Ph. 02 62050794 | Fax. 02 62072544
 Licensing and Compliance, City Services, Parks and City Services | Territory and Municipal Services Directorate |
 ACT Government
 Stromlo Office, 500 Cotter Rd, Weston Act 2611 | GPO Box 158 Canberra ACT 2601 | www.act.gov.au

From: TAMS, Permit Approvals
Sent: Monday, 10 December 2012 1:30 PM
To: Pittard, Scott
Subject: Permlt_465

Hi Scott,

Permit 465 attached
<G:\DATAB\PACS Permits\Applications\465 NS.pdf>

Regards

Shannon Walker | A/G Permits officer |
 Phone 02 62058794 | Fax 02 62072544 | Email: shannon.walker@act.gov.au
 Place Management, City Services, Licensing and Compliance | Territory and Municipal Services Directorate | ACT Government
 Stromlo Depot | GPO Box 158 Canberra ACT 2601 | www.act.gov.au

Application to undertake nature strip development Cover sheet			
Permit No: 00465	Date received: 10/12/2012	Decision Date:	Status: Under Consider'n
Address:	[Redacted] Banks		
Name of Applicant:	[Redacted]		
Applicants contact details	Phone (W):	Phone (H):	
	Mob: [Redacted]	Email: [Redacted].com.au	
Details: Bollards, trees			
Comments: RE-GRASSING IS ACCEPTABLE.			
District Manager			
<input type="checkbox"/> Y	<input type="checkbox"/> N	Retaining wall installation	Comments:
<input type="checkbox"/> Y	<input type="checkbox"/> N	Existing nature strip trees	Comments:
<input type="checkbox"/> Y	<input type="checkbox"/> N	Watering System installed	Comments:
<input checked="" type="checkbox"/> Y	<input type="checkbox"/> N	Suitability of trees selected	Comments: UNSUITABLE TREES TO COMMENT
<input type="checkbox"/> Y	<input type="checkbox"/> N	Suitability of plants selected	Comments:
<input type="checkbox"/> Y	<input type="checkbox"/> N	Existing plants	Comments:
<input checked="" type="checkbox"/> Y	<input type="checkbox"/> N	Pedestrian access	Comments: BOLLARDS TO BE SET BACK MIN. 1.2 METRES FROM BACK OF ROAD - CLAUSE 12 IN TERMS & CONDITIONS
<input type="checkbox"/> Y	<input type="checkbox"/> N	Storage of materials on N/S	Comments:
<input type="checkbox"/> Y	<input type="checkbox"/> N	Installation of mulch	Comments:
<input type="checkbox"/> Y	<input type="checkbox"/> N	Installation of granite	Comments:
<input checked="" type="checkbox"/> Y	<input type="checkbox"/> N	Bollards	Comments: NEED TO REFER TO CLAUSE 12 IN THE TERMS AND CONDITIONS
<input type="checkbox"/> Y	<input type="checkbox"/> N	Line of sight	Comments:
<input checked="" type="checkbox"/> Y	<input type="checkbox"/> N	UTILITY CLEARANCES	Comments: MUST BE OBTAINED PRIOR TO COMMENCEMENT OF WORKS
Refer to			
Tree Management Date 10/12/12	Roads ACT Date / /	Sportsground & Facilities Date / /	Bushfire Date / /
Recommendation			
Approval		Approval Pending	Non Approval

Inspecting Officer:

SCOTT PITMAN

Date 10/12/12

Nature Strip Development Application
[REDACTED] Banks ACT 2906



9th December, 2012

Dear Sir/Madam,

I am writing to put in an application for our nature strip for your consideration, over the past 12 months I have been having correspondence backwards and forwards relating to the neighbourhood using the nature strip as a car park.

We are looking to get approval to be able to place bollards along the nature strip as per drawn on attached Plan "A". I have also attached many photos highlighting the extent of the cars that park on the nature strip from time to time. The problem with this is that they park within metres of the house at all hours and between the lights shining in our home, the noise so close and the total lack of understanding with neighbours, we have had enough to say the least.

We would look at putting in the bollards in line with the recommendations of 1.2m parallel to the road and our laneway Marked "B" to stop them driving up and parking out our front door also. We would look to have the Item "D" bollards removal to allow any future machinery that would need access to the sewerage line or other areas on the property as required.

We are also looking at whether the right area could look at planting a few trees in the area marked "C" in the drawing to keep in line with the street appeal. There is evidence of a tree or two there before that have been removed pre our time living here. With that we would also look at grassing the area from the inside proposed bollards to the property line to help stop the dust blowing in through our home.

[REDACTED] and I would of have had this application sent in earlier this year as per our attached emails, though unfortunately we have had a couple of [REDACTED] [REDACTED] and haven't got around to filling out this application due to the [REDACTED]

We are hoping that we can get this approval approved and underway as soon as possible and start to arrange some quotes to get this underway before the festive season finishes.

We appreciate your help and support with this matter.

Regards,
[REDACTED]



Plan "A"

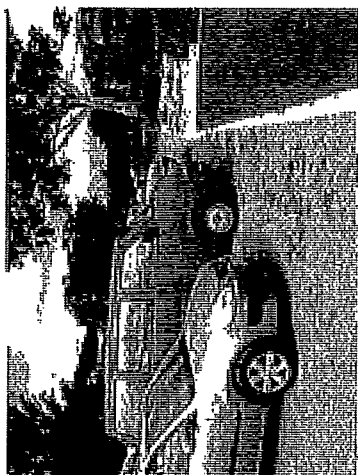
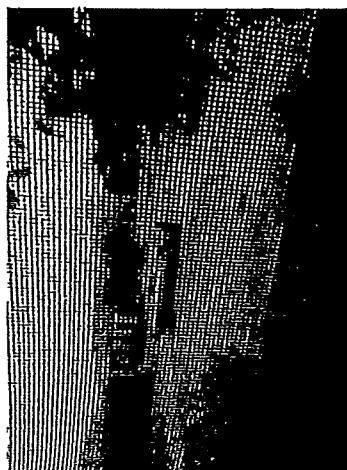
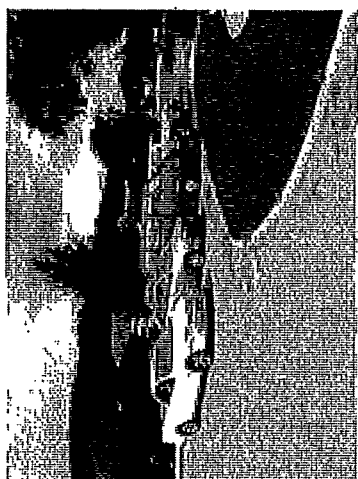
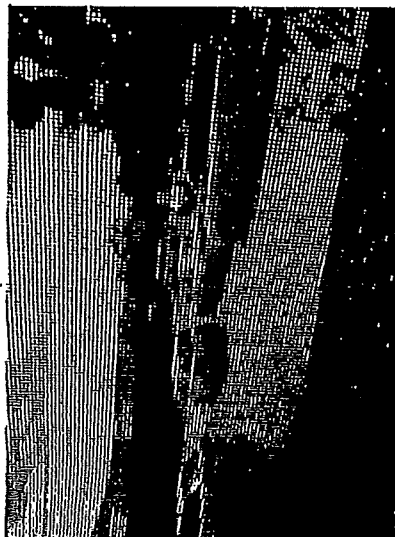

Walker, Shannon

From: Plttard, Scott
Sent: Monday, 10 December 2012 3:03 PM
To: TAMS, Permit Approvals
Subject: RE: Permit_465
Attachments: 201212101501.pdf.pdf

Approval pending advise from Urban Treescapes

Scott Plttard | Southside Technical Support Officer |
Phone 02 62075435 | Fax 02 62075966 | Email Scott.plttard@act.gov.au
Place Management, City Services, Parks and City Services | Territory and Municipal Services Directorate | ACT Government
Level 8, Macarthur House, 12 Wattle Street, Lyneham ACT 2602 | GPO Box 158 Canberra ACT 2601 | www.act.gov.au

From: TAMS, Permit Approvals
Sent: Monday, 10 December 2012 1:30 PM
To: Plttard, Scott
Subject: Permit_465

Hi Scott,

Permit 465 attached
<G:\DATA\B\PACS Permits\Applications\465 NS.pdf>

Regards

Shannon Walker | A/G Permits officer |
Phone 02 62058794 | Fax 02 62072544 | Email: shannon.walker@act.gov.au
Place Management, City Services, Licensing and Compliance | Territory and Municipal Services Directorate | ACT Government
Stromlo Depot | GPO Box 158 Canberra ACT 2601 | www.act.gov.au

Walker, Shannon

From: Leavesley, Adam
Sent: Tuesday, 18 December 2012 12:49 PM
To: TAMS, Permit Approvals
Subject: RE: Permit_465

Dear All,

The FMU does not have any concerns with this proposal.

Cheers, Adam

From: TAMS, Permit Approvals
Sent: Friday, 14 December 2012 9:05 AM
To: Leavesley, Adam
Subject: Permit_465

Hi Adam,

Permit 465 attached

<G:\DATAB\PACS Permits\Applications\465 NS.pdf>

Regards

Shannon Walker | A/G Permits officer |
Phone 02 62058794 | Fax 02 62072544 | Email: shannon.walker@act.gov.au
Place Management, City Services, Licensing and Compliance | Territory and Municipal Services Directorate | ACT Government
Stromlo Depot | GPO Box 158 Canberra ACT 2601 | www.act.gov.au

Application to undertake nature strip development Cover sheet			
Permit No: 00465		Date received: 10/12/2012	Decision Date:
Address:		Status: Under Consider'n	
Name of Applicant:		Banks	
Applicants contact details		Phone (W):	Phone (H):
		Mob:	Email:
Details: Bollards, trees			
Comments:			
District Manager			
Y	N	Retaining wall Installation	Comments:
Y	N	Existing nature strip trees	Comments:
	N	Watering System Installed	Comments:
Y	N	Suitability of trees selected	Comments:
Y	N	Suitability of plants selected	Comments:
Y	N	Existing plants	Comments:
Y	N	Pedestrian access	Comments:
Y	N	Storage of materials on N/S	Comments:
✓	N	Installation of mulch	Comments:
Y	N	Installation of granite	Comments:
Y	N	Bollards	Comments:
Y	N	Line of sight	Comments:
Y	N		Comments:
Refer to			
Tree Management		Roads ACT	Sportsground & Facilities
Date / /		Date / /	Bushfire Date / /
Recommendation			
Approval		Approval Pending	Non Approval

Inspecting Officer: _____

Date / /



Australian Capital Territory
Territory and Municipal Services
**NATURE STRIP DEVELOPMENT
APPLICATION**

Return to: Stromlo Office
City Services
GPO Box 158 Canberra ACT 2601
Telephone: Canberra Connect 13 22 81
Fax: (02) 8207 2544
environment_eventsandocamping@aot.gov.au

A minimum of 14 days is required for processing

Permit No:
(Office use only) **A-65**

Application Requirements

Detailed sketch plan - (to scale) of your proposal on a separate sheet of paper.

Details are to include the location of existing footpaths, landscape features, watering systems and nature strip trees, include measurements, plant names (common and botanical) and their proposed location, types of mulch and any other landscape materials to be used.

Trees will only be approved if they match the landscape character for the street. You must also take into account the mature size of plants, to ensure they will not cause an obstruction for pedestrians or line of sight problems for motorists.

Watering systems may be approved, subject to tree protection requirements. Include locations any existing system and method of installation (what excavation is proposed), details of proposed water regime and how it will be controlled.

The lease holder(s), body corporate manager or legally appointed representative(s) must complete and sign the form.

Applicants Details

Name of Organisation (if applicable)

[Empty box for Name of Organisation]

Name of Applicant

Surname [Redacted] Given Name [Redacted]

Applicants Address

[Redacted] Suburb **BANKS** State **ACT** Postcode **2906**

Email Address

[Redacted] ABN (if applicable) [Redacted] ACN (if applicable) [Redacted]

Telephone Business Hrs

[Redacted] Mobile [Redacted] Fax [Redacted]

Locality Details (include map)

Applicants Address (if different from above)

[Empty box] Suburb [Empty box] State [Empty box] Postcode [Empty box]

Other requests

.....
..... **PLEASE SEE ATTACHED**

..... **Request for Ballards & TREES**

.....
.....
.....
.....

Applicant signature	
<input checked="" type="checkbox"/>	I acknowledge and accept all attached standard conditions & will also abide by any additional conditions attached on approval.
Signature	Date <u>09/12/12</u> Witness
Office use only	
<input checked="" type="checkbox"/> Approved	<input type="checkbox"/> Not approved
..... 6/2/13 on behalf of	
Australian Capital Territory	
This approval is to be produced on demand by Police or Authorised Officer	
Address	Suburb
.....	Banks

Additional Conditions

Urban Trees has consulted applicant regarding tree plantings.....
 please see attached notes on ballard installation.....
 (see also condition 12 in Terms & Conditions.)

Notes:

- An applicant is required to obtain approval to temporarily store any material on the nature strip. Materials such as soil, mulch and sand directly related to the development of the nature strip
- Permission will not be given for the storage on unleased land of reinforcing mesh, roofing iron, glazed windows or any other materials which in the opinion of the Australian Capital Territory ("The Territory") are likely to be dangerous. Only safe structures will be approved.
- Trenching or excavation may not be approved if it is likely to affect existing trees.
- It is illegal to park or store any type of vehicles or trailers on a nature strip.
- The suitability of the plant species proposed will be assessed for each site.

Conditions and Terms**Landscape Development**

- Landscape development may include the following features: garden beds, rockeries, paving, trees, shrubs, ground cover plants, tan bark or similar materials.
- Tan bark, wood chips, loose soil or other material will only be approved if stable and suitably contained.
- If you wish to remove any trees that you or a previous lessee have planted on the nature strip, you are required to obtain written approval from Parks Conservation and Lands before removing the tree. Telephone 132281.
- If you do not have a street tree and would like one planted, contact Parks, Conservation and Lands on telephone 132281.

Street Tree Protection Requirements

- Adequate protection for nature strip trees is required. This can be achieved by:
 - no unapproved excavation within the drip line of trees;
 - no excavation for services, driveways, or footings within at least 3m of the tree trunk;
 - avoiding hard paving surfaces which create an impermeable layer, preventing air and water from reaching tree roots, stop paving at least 500mm from the trunk of the tree and provide a gravel diffusion layer under the pavement; and
 - ensuring that the ground level around nature strip trees is not altered and that materials are not to be built-up around the base of any trees.

Pedestrian Access, Line of Sight and/or Obstructions

- A strip of grass or stable surface a minimum of 1.2 metres wide must be maintained at the back of kerb for pedestrian access. No obstruction is permitted within this 1.2 metre wide strip. Any edging must be flush with the adjacent ground.
- Foliage which is on the nature strip, or growing on your lease and overhangs a footpath, must be pruned to maintain a minimum height of 2 metres clear above footpaths and pruned back in line with the edge of the footpath (including hedges and groundcovers). For safety purposes, pedestrians must have access to the entire width of the footpath.
- Foliage or structures are not to cause a line of sight problem for vehicles or pedestrians when using, entering or exiting an intersection, driveway or footpath.
- Where a lease is adjacent to a pedestrian laneway which meets a road, extra provision for line of sight must be considered.
- Grass should be kept below 0.5 of a metre, to ensure that it does not cause a line of sight problem or a fire hazard.

Log Barriers and Bollards

11. Log barriers - Are generally not approved on the nature strip.
12. Bollards - vertical posts (100-150mm in diameter) are permitted on the nature strip provided they are positioned a minimum of 1.2 metres from the back of the kerb. They are to be erected with a gap of a minimum of 1.2 metres between each bollard and extend a minimum of 800mm in height above the ground. A row of bollards can be erected at right angles to the road provided they are positioned a minimum of 1.2 metres from any driveway or footpath.
13. Temporary protective fencing is permitted with approval, if constructed and maintained in a safe condition, in areas where newly seeded soil or turf is located. Protective fencing must be clearly marked with reflective tape or similar materials etc. Permanent fencing is not permitted.

Watering System

14. The system must be regulated and maintained so that water does not fall on the footpath (where provided), roadway or adjacent driveway(e) under normal weather conditions.
15. The requirements of public utility authorities, (eg, gas, telephone, electricity) must be met concerning installation procedure where services are contained within the road verge.
16. Should the need arise for maintenance of any public utility or tree contained within the road verge, the Territory will not be held responsible for any damage to the watering system.
17. The Territory will not be responsible for any damage caused to the watering system by roots of trees planted or maintained by the Territory.
18. The watering system when operating, is to cause minimal inconvenience to pedestrians and must be kept in good repair (ie, no leaking sprinklers over footpaths and down gutters).

Sound

The Environment Protection Act 1987 and the Environment Protection Regulation 2005 has established noise emissions standards for the ACT. The Applicant is to ensure that noise from mechanical plant complies with these noise standards at all adjoining properties. The noise standards are set out below.

Location	7am-10pm (8am-10pm Sunday & Public Holidays)	10pm-7am (10pm-8am Sunday & Public Holidays)
Olivo centre and other major town centres (Belconnen, Gungahlin, Woden and Tuggeranong)	60 dB(A)	50dB(A)
Group centres such as Dikson and Kingston	55 dB(A)	46dB(A)
Smaller local centres such as Griffith and Lynsham	50dB(A)	36dB(A)
Residential Areas	46dB(A)	36dB(A)

Management of Land by Applicant

20. The area shall be managed by the Applicant in an orderly and safe manner. When vacated it should be left in a clean and tidy condition and reinstated with topsoil and grass to the satisfaction of the Territory and at no expense to the Territory.
21. Any damage to grassed surfaces, footpaths, kerbs and gutters, trees, irrigation systems or any other installations or services contained within the unleased land must be fully restored by the Applicant, to the complete satisfaction of the Territory and at no expense to the Territory.

ACT Government Requirements

22. Should the need arise, the area is to be vacated within a period specified by the Territory, at no expense to the Territory.
23. Should the need arise for the installation, maintenance or erection of any public utility or Territory improvement on the unleased land the Territory or public utility provider will not be held responsible for restoration of any substance, material or item affected by the said installation or erection.
24. If this application is approved, all costs arising out of the Applicant's use of the unleased land, including the relocation of any engineering services, will be borne by the Applicant.
25. The Territory reserves the right to withdraw, make changes to, or change the conditions to an approved application at any time. Changes are to be completed at no expense to the Territory.
26. In the case of a nature strip development, should the applicant resolve to sell his/her lease, he/she will, prior to such disposal, supply the Territory with the name and address of the intending purchaser. The new owner must in writing agree to continue this contract and adhere to the above conditions, or reinstate the area back to its original grass condition to the satisfaction of the Territory.

LOG BOLLARD

Before installation of the bollards, Dial Before You Dig, 1100, must be contacted to ascertain if any services are in the digging/post hole zone.

Log bollards: tanalith treated pine logs 120-200mm in diameter and at least 1.5m long or recycled plastic bollards 1.5m long, for urban areas.

Posts must be at least 600mm below ground surface and 900mm above ground level and concreted in place.

Posts to be spaced at 1.2m intervals, from the outside of post to outside of the next post.

Posts to be installed at 1.2m, measured from the back of the concrete kerb to the outside edge of the post, along the line of the kerb.

A 100mm wide mowing edge can be put around the post, using the cement from the installation.

Posts are to be sighted/string lined to maintain an even appearance.

If there is a tree on the nature strip that will be in the line of bollards then information from City Services, Urban Treescapes will be required. Call Canberra Connect 13 22 81.

Log Bollards

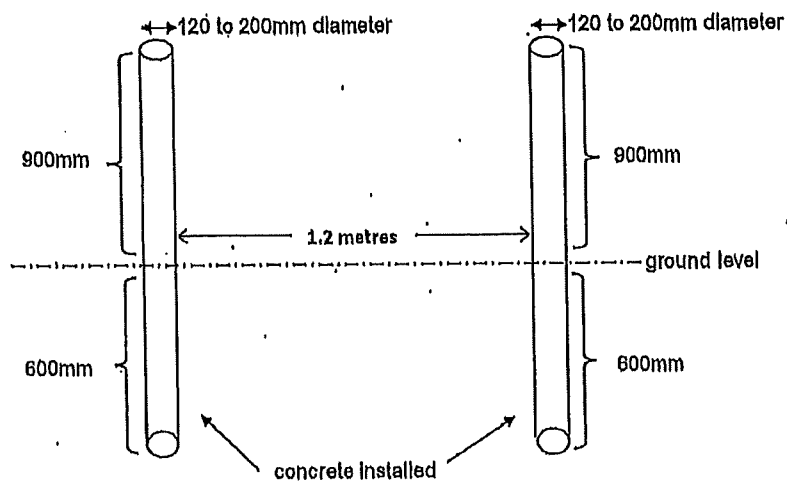

NB: Not to scale.

Potter, Matt

From: [REDACTED]
Sent: Monday, 14 January 2013 8:58 PM
To: Potter, Matt
Cc: Pittard; Scott; Boersma, Timo; [REDACTED]
Subject: Fwd: verge parking

Importance: High

Hi Matt,

Unsure if you are getting Darren's emails, though I'm hoping that you may be able to help us out with an update.

Appreciate your help
[REDACTED]

Begin forwarded message:

From: [REDACTED]
Subject: Re: verge parking
Date: 14 January 2013 8:53:56 PM AEDT
To: Darren Gerrard <Darren.Gerrard@act.gov.au>, Scott Pittard <Scott.Pittard@act.gov.au>, Timo Boersma <Timo.Boersma@act.gov.au>
Cc: [REDACTED]

Good evening Darren,

Happy New Year, hope you had a good festive break.

I was wondering if you are getting close to giving us an update on our application. Just as a support I have included a couple of more photos that cement the application that we had to put up with over the Christmas break.

Look forward to hearing from you soon

Regards,
[REDACTED]

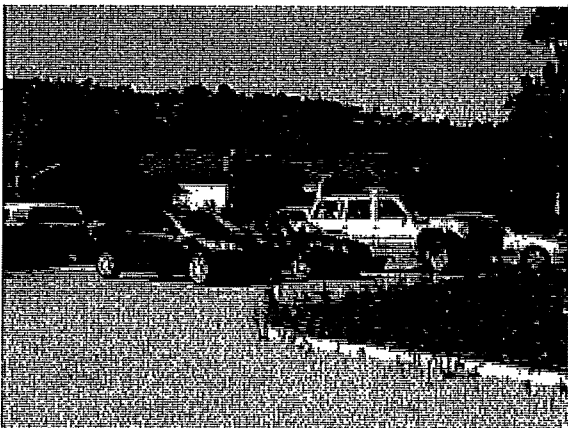

Subject: RE: verge parking

Date: 17 April 2012 7:52:03 AM AEST

To: [REDACTED]

Cc: "Gerrard, Darren" <Darren.Gerrard@act.gov.au>, "Pittard, Scott" <Scott.Pittard@act.gov.au>

[REDACTED]

The nature strip application needs to go to Darren Gerrard. He will consult with Scott as part of the assessment process.

Cheers

Timo Boersma | Manager, Land Use Unit | Licensing and Compliance Section
City Services Branch | Parks and City Services Division
Territory and Municipal Services Directorate | ACT Government
Tel (02) 6205 4766 | Email: timo.boersma@act.gov.au

From: [REDACTED]
Sent: Monday, 16 April 2012 7:04 PM
To: Boersma, Timo
Subject: Re: verge parking

Hi Timo,

Thank you again for your support and keeping us updated. [REDACTED] and I are in the process of putting in a Nature Strip Development into Scott for consideration.

Lets see how we go,

Many thanks
[REDACTED]

On 16/04/2012, at 7:44 AM, Boersma, Timo wrote:

[REDACTED]

FYI

Timo Boersma | Manager, Land Use Unit | Licensing and Compliance Section
City Services Branch | Parks and City Services Division
Territory and Municipal Services Directorate | ACT Government
Tel (02) 6205 4766 | Email: timo.boersma@act.gov.au

From: Lyons, CollinP
Sent: Monday, 16 April 2012 7:26 AM
To: Boersma, Timo
Subject: RE: verge parking

G'day Timo,

Sorry I have been on leave, I have asked the supervisors to put some more pressure on the area.

the officers can issue warnings to the offending cars (they do work on weekends). If that doesn't work, then a physical barrier may need to be considered.

The Land Manager, Scott Pittard, will investigate the possibility of bollards or other form of nature strip development. If that continues to be your wish, you will need to apply for a nature strip development approval from the Public Use Coordinator, Darren Gerrard on (02) 6205 7245.

Regards

Timo Boersma | Manager, Land Use Unit | Licensing and Compliance Section
City Services Branch | Parks and City Services Division
Territory and Municipal Services Directorate | ACT Government
Tel (02) 6205 4766 | Email: timo.boersma@act.gov.au

This email, and any attachments, may be confidential and also privileged. If you are not the intended recipient, please notify the sender and delete all copies of this transmission along with any attachments immediately. You should not copy or use it for any purpose, nor disclose its contents to any other person.

Ireland-Bell, Bronwyn

From: Boersma, Timo
Sent: Tuesday, 10 April 2012 8:02 AM
To: [REDACTED]
Cc: Pittard, Scott; Gerrard, Darren; [REDACTED]
Subject: RE: verge parking

[REDACTED]

Did you talk to Darren Gerrard about a permit to put in bollards as mentioned below?

regards

Timo Boersma | Manager, Land Use Unit | Licensing and Compliance Section

City Services Branch | Parks and City Services Division

Territory and Municipal Services Directorate | ACT Government

Tel (02) 6205 4766 | Email: timo.boersma@act.gov.au

From: [REDACTED]
Sent: Friday, 6 April 2012 11:09 AM
To: Boersma, Timo
Cc: Pittard, Scott; Lyons, CollinP
Subject: RE: verge parking
Importance: High

Good morning Timo,

Sorry to bother you again, though [REDACTED] and I are at our wits end with people just thinking the front of our house is a public car park, with no parking operations today and always continuous parking late at night we are sick of people parking only metres from our home. There are about a dozen cars parked outside our windows presently.

Attached are some photos of this morning. Could we please look at getting some bollards or barriers put in as this is becoming unacceptable. If you are not able to help could you please supply further details for us to peruse. We really need some support, help and action on this please!

Look forward to hearing from you.

[REDACTED]

From: Boersma, Timo [mailto:Timo.Boersma@act.gov.au]

Sent: Tuesday, 6 March 2012 2:40 PM

To: [REDACTED]

Cc: Pittard, Scott; Lyons, CollinP

Subject: verge parking

[REDACTED]

Could you please send me your photos in relation to the illegal verge parking at [REDACTED] Banks. In the first instance, could you please call the parking operations on 6207 7200 when you see the unauthorised parking, so that the officers can issue warnings to the offending cars (they do work on weekends). If that doesn't work, then a physical barrier may need to be considered.

The Land Manager, Scott Pittard, will investigate the possibility of bollards or other form of nature strip development. If that continues to be your wish, you will need to apply for a nature strip development approval from the Public Use Coordinator, Darren Gerrard on (02) 6205 7245.

Regards

Timo Boersma | Manager, Land Use Unit | Licensing and Compliance Section

City Services Branch | Parks and City Services Division

Territory and Municipal Services Directorate | ACT Government

Tel (02) 6205 4766 | Email: timo.boersma@act.gov.au

This email, and any attachments, may be confidential and also privileged. If you are not the intended recipient, please notify the sender and delete all copies of this transmission along with any attachments immediately. You should not copy or use it for any purpose, nor disclose its contents to any other person.

Ireland-Bell, Bronwyn

From: Boersma, Timo
Sent: Tuesday, 10 April 2012 8:03 AM
To: Lyons, CollinP; Pittard, Scott; Gerrard, Darren
Subject: FW: verge parking
Attachments: IMG_1762.JPG; IMG_1764.JPG; IMG_1765.JPG; IMG_1767.JPG; IMG_1768.JPG; IMG_1765.JPG

Importance: High

Timo Boersma | Manager, Land Use Unit | Licensing and Compliance Section

City Services Branch | Parks and City Services Division

Territory and Municipal Services Directorate | ACT Government

Tel (02) 6205 4766 | Email: timo.boersma@act.gov.au

From: [REDACTED]
Sent: Friday, 6 April 2012 11:09 AM
To: Boersma, Timo
Cc: Pittard, Scott; Lyons, CollinP
Subject: RE: verge parking
Importance: High

Good morning Timo,

Sorry to bother you again, though [REDACTED] and I are at our wits end with people just thinking the front of our house is a public car park, with no parking operations today and always continuous parking late at night we are sick of people parking only metres from our home. There are about a dozen cars parked outside our windows presently.

Attached are some photos of this morning. Could we please look at getting some bollards or barriers put in as this is becoming unacceptable. If you are not able to help could you please supply further details for us to peruse. We really need some support, help and action on this please!

Look forward to hearing from you.

[REDACTED]

From: Boersma, Timo [mailto:Timo.Boersma@act.gov.au]
Sent: Tuesday, 6 March 2012 2:40 PM
To: [REDACTED]
Cc: Pittard, Scott; Lyons, CollinP
Subject: verge parking

[REDACTED]

Could you please send me your photos in relation to the illegal verge parking at [REDACTED] Banks. In the first instance, could you please call the parking operations on 6207 7200 when you see the unauthorised parking, so that the officers can issue warnings to the offending cars (they do work on weekends). If that doesn't work, then a physical barrier may need to be considered.

The Land Manager, Scott Pittard, will investigate the possibility of bollards or other form of nature strip development. If that continues to be your wish, you will need to apply for a nature strip development approval from the Public Use Coordinator, Darren Gerrard on (02) 6205 7245.

Regards

Timo Boersma | Manager, Land Use Unit | Licensing and Compliance Section

City Services Branch | Parks and City Services Division

Territory and Municipal Services Directorate | ACT Government

Tel (02) 6205 4766 | Email: timo.boersma@act.gov.au

This email, and any attachments, may be confidential and also privileged. If you are not the intended recipient, please notify the sender and delete all copies of this transmission along with any attachments immediately. You should not copy or use it for any purpose, nor disclose its contents to any other person.



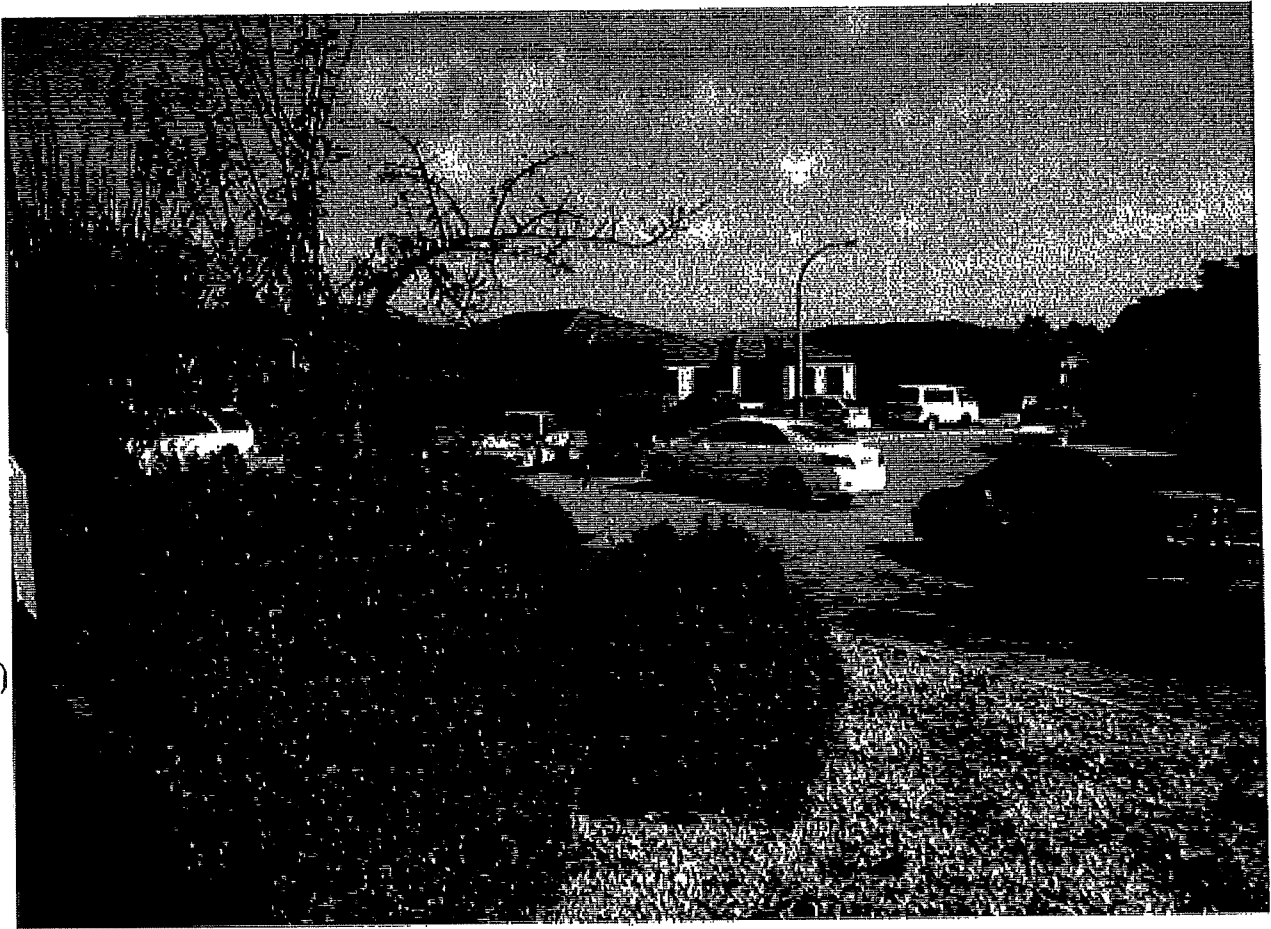

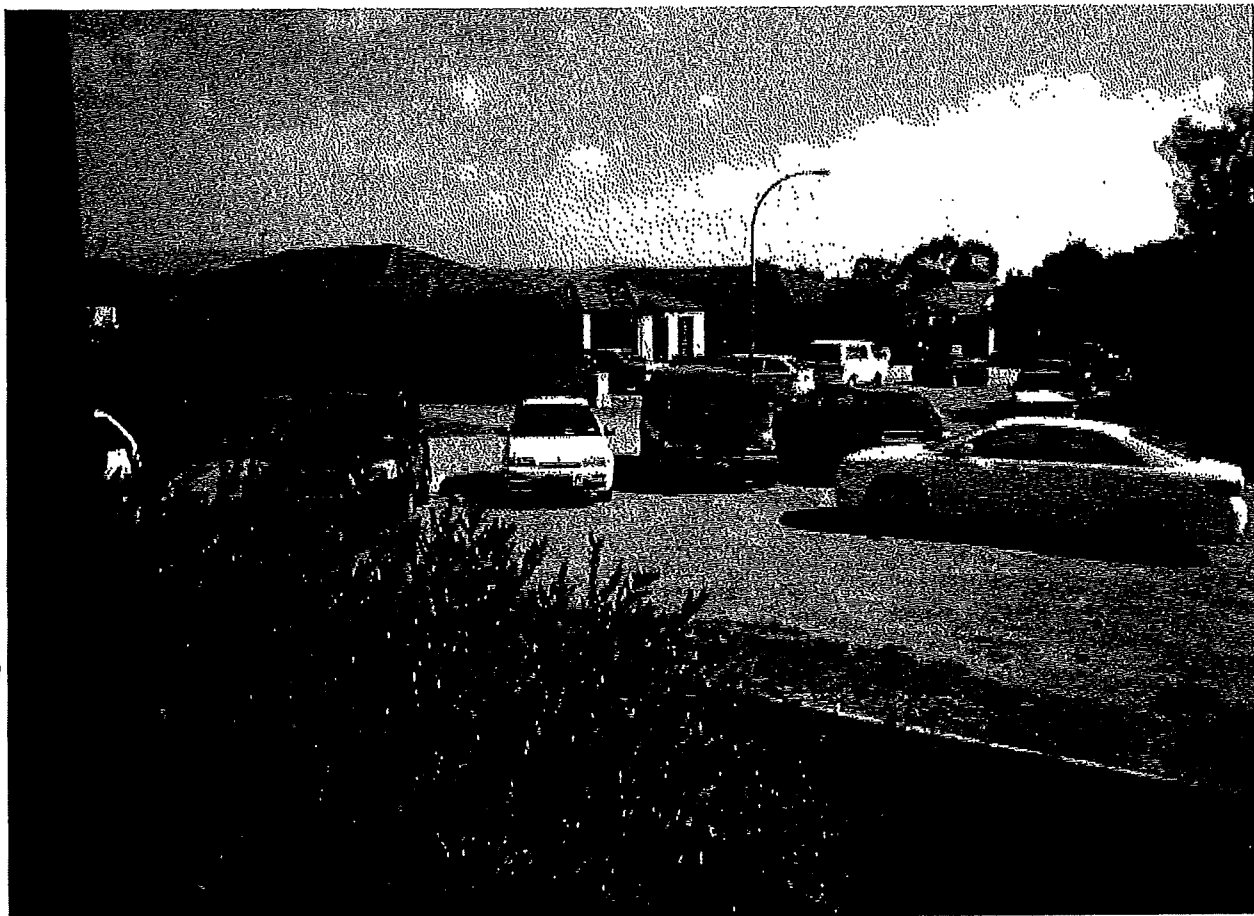

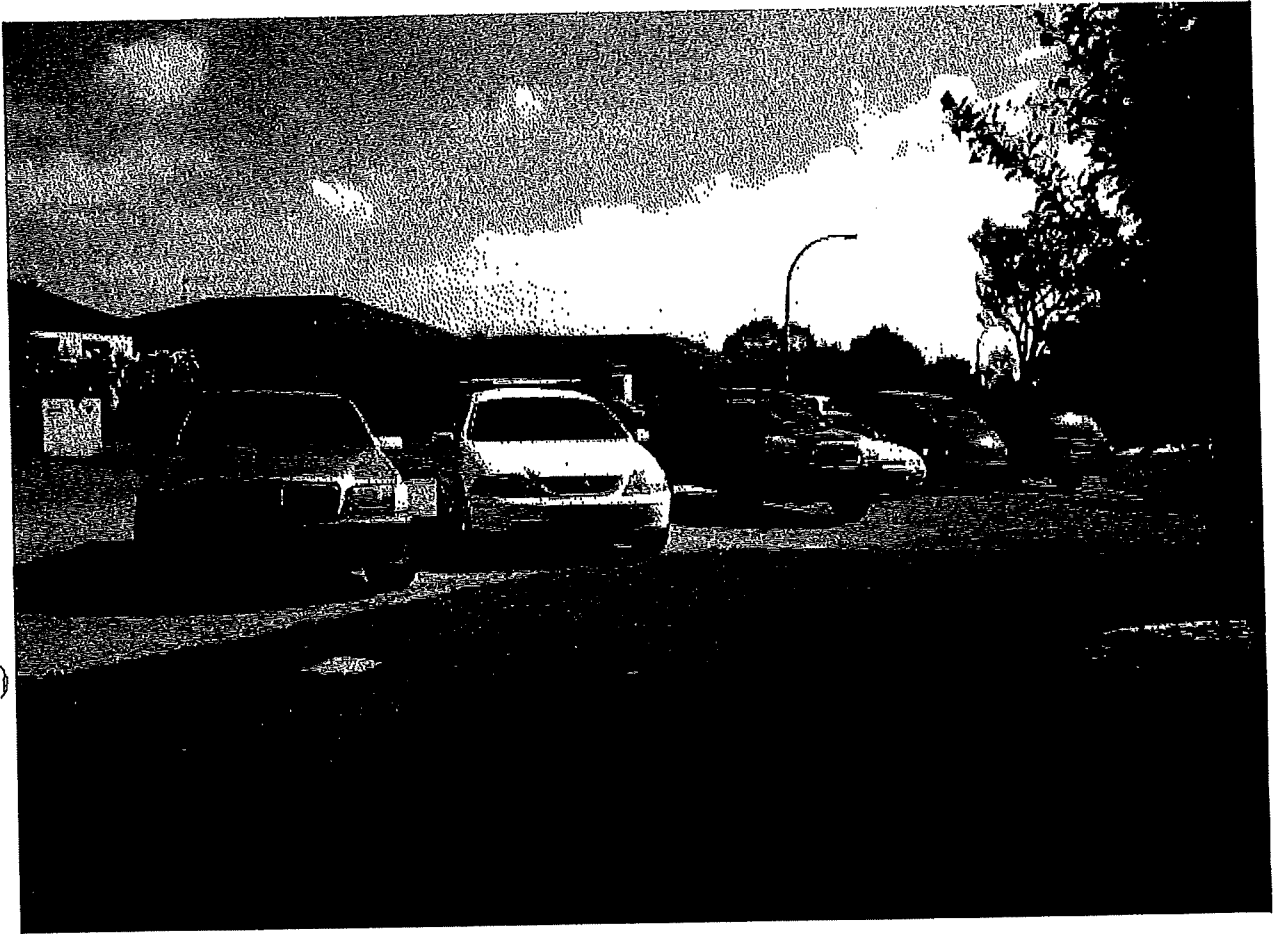

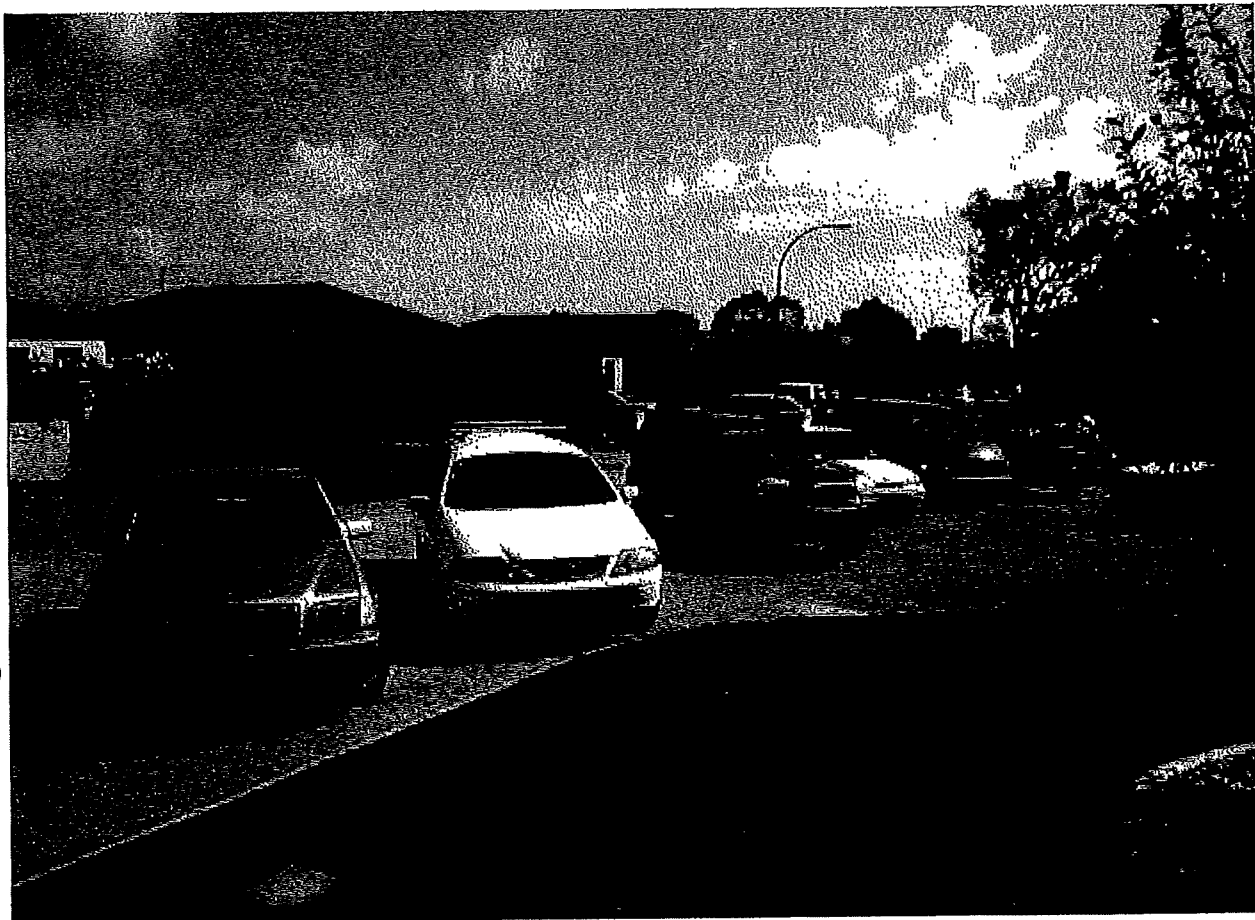

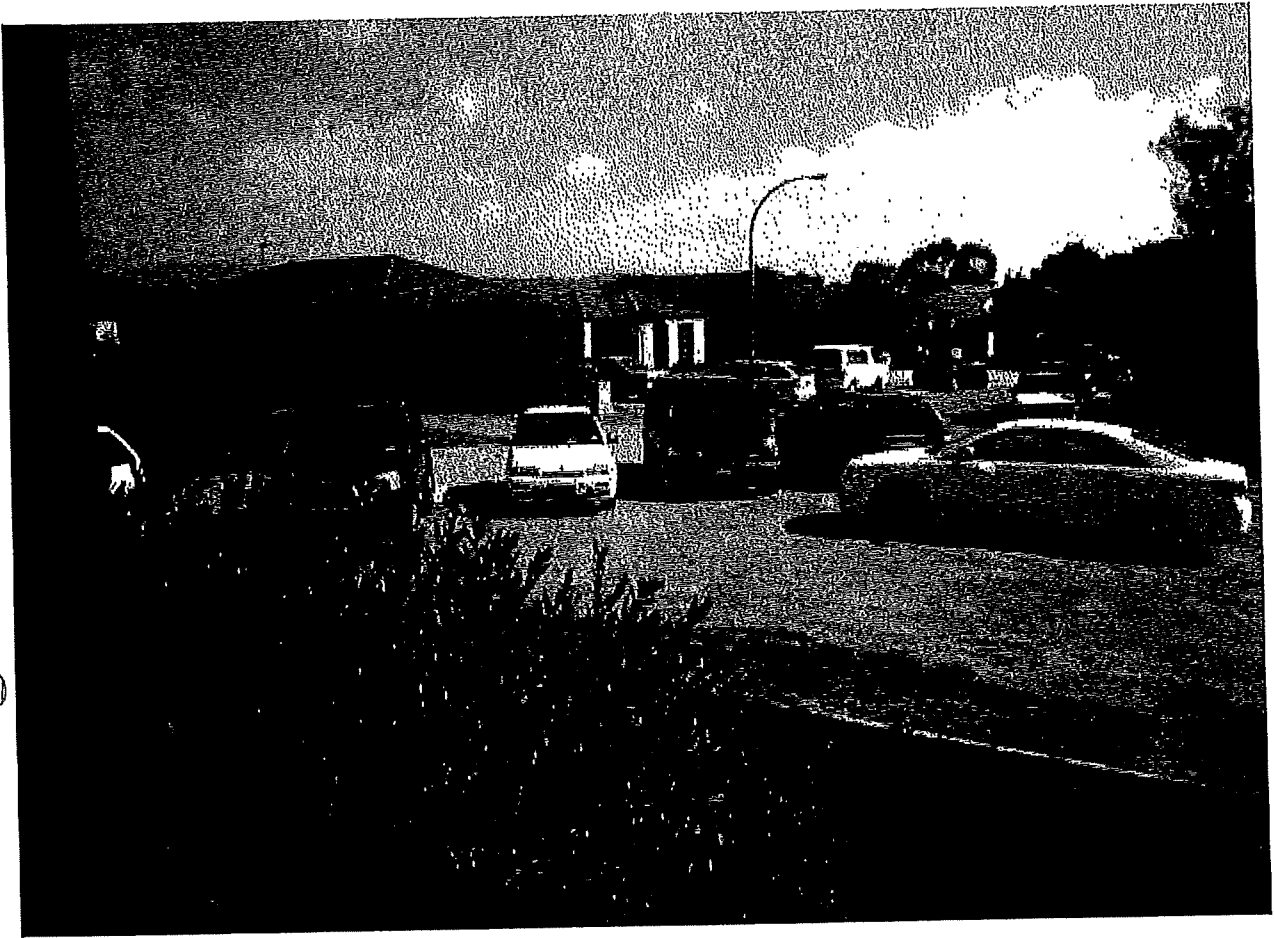

Ireland-Bell, Bronwyn

From: [REDACTED]
Sent: Tuesday, 10 April 2012 1:52 PM
To: Boersma, Timo
Cc: Pittard, Scott; Gerrard, Darren; [REDACTED]
Subject: Re: verge parking

Hi Timo,
Thanks for your email.
I have left a message for Scott to give me a call back. Hope he can help us out and steer us in the right direction.
Regards,
[REDACTED]

Sent from my iPad

On 10/04/2012, at 8:02 AM, "Boersma, Timo" <Timo.Boersma@act.gov.au> wrote:

Did you talk to Darren Gerrard about a permit to put in bollards as mentioned below?

regards

Timo Boersma | Manager, Land Use Unit | Licensing and Compliance Section

City Services Branch | Parks and City Services Division

Territory and Municipal Services Directorate | ACT Government

Tel (02) 6205 4766 | Email: timo.boersma@act.gov.au

From: [REDACTED]
Sent: Friday, 6 April 2012 11:09 AM
To: Boersma, Timo
Cc: Pittard, Scott; Lyons, Collin
Subject: RE: verge parking
Importance: High

Good morning Timo,

Sorry to bother you again, though [REDACTED] and I are at our wits end with people just thinking the front of our house is a public car park, with no parking operations today and always continuous parking late at night we are sick of people parking only metres from our home. There are about a dozen cars parked outside our windows presently.

Attached are some photos of this morning. Could we please look at getting some bollards or barriers put in as this is becoming unacceptable. If you are not able to help could you please supply further details for us to peruse. We really need some support, help and action on this please!

Look forward to hearing from you.

[REDACTED]

From: Boersma, Timo [mailto:Timo.Boersma@act.gov.au]
Sent: Tuesday, 6 March 2012 2:40 PM
To: [REDACTED]
Cc: Pittard, Scott; Lyons, Collin P
Subject: verge parking

[REDACTED]

Could you please send me your photos in relation to the illegal verge parking at [REDACTED] Banks. In the first instance, could you please call the parking operations on 6207 7200 when you see the unauthorised parking, so that the officers can issue warnings to the offending cars (they do work on weekends). If that doesn't work, then a physical barrier may need to be considered.

The Land Manager, Scott Pittard, will investigate the possibility of bollards or other form of nature strip development. If that continues to be your wish, you will need to apply for a nature strip development approval from the Public Use Coordinator, Darren Gerrard on (02) 6205 7245.

Regards

Timo Boersma | Manager, Land Use Unit | Licensing and Compliance Section

City Services Branch | Parks and City Services Division

Territory and Municipal Services Directorate | ACT Government

Tel (02) 6205 4766 | Email: tmo.boersma@act.gov.au

This email, and any attachments, may be confidential and also privileged. If you are not the intended recipient, please notify the sender and delete all copies of this transmission along with any attachments immediately. You should not copy or use it for any purpose, nor disclose its contents to any other person.

Ref No.	Date Created	Street	Closest address	Suburb list	Comments
180126-000484	26/01/2018 08.06 PM	No Value	██████████ Banks ACT 2906, Australia	Gordon	The nature strip in front of # ██████████ Banks has been fenced off by a private individual, and is overgrown with weeds and empty garden beds. It is a hideous eyesore.
131126-002300	26/11/2013 03.53 PM	██████████	No Value	Banks	Nature strip has been developed with logs vertical out of ground at bend in road